



**TAN Bead Nucleic Acid Extractor
(Non-Sterile)**

039.M17RU.X02















Maelstrom Switch 8 User Manual

Contents

1.	Introduction	6
2.	Instrument Overview	12
3.	Instrument Specification.....	19
4.	Installation & Get started.....	20
5.	Software Applications.....	30
6.	Technical Support	55
7.	Cleaning and Maintenance	56
8.	Disposal	56
9.	Patent	57
10.	About Manufacturer	57
11.	Advisory Notices.....	57
12.	TANBead Instrument Warranty Policy.....	58

About Manual

The label on the instrument, User Manual, and other packaging material may contain following symbols:

- | | | | |
|---|---|---|---|
|  REF | Catalog number |  | Temp limit |
|  SN | Serial number |  | Keep dry |
|  | Manufacturer |  | Keep away from sunlight |
|  | The date of manufacture |  | Biologic risks |
|  | Non-sterile |  | Humidity limit |
|  | Biologic risks |  | Instructions for Use
<small>eIFU Indicator</small> |
|  | Hot surface, risk of burns | | |
|  | Caution | | |
|  | The WEEE symbol, indicating separate collection for WEEE-
Waste of electrical and electronic equipment | | |

About Instrument

Warning

- Use a power cord that meets your country's standard. In case of any questions, contact your local distributor for assistance.
- Maelstrom Switch 8 operates within the voltage range from 100 Volts to 240 Volts.
- Do not use the instrument with a damaged power cord or a loose socket.
- To unplug, hold the power plug itself instead of pulling the power cord.
- Prior to performing the maintenance, make sure to unplug the power plug from the outlet.
- Do not pour any liquid on the instrument.
- Do not place any containers with liquid on the instrument. Doing so may cause a fire, an electric shock or malfunctions of the instrument.
- Do not touch the power plug or cord if there is a chance of lightning. Failure to observe this may cause electric shocks.
- If you hear a thunder or suspect an approaching lightning when in use, turn off the power switch and disconnect the power plug immediately. Failure to observe this may cause a fire or malfunctions.

About Instrument

Caution

- Never attempt to remodel the instrument without the permission from the manufacturer. Doing so may lead to a fire or an electric shock.
- Do not subject the instrument to any impacts and do not knock it. Doing so may cause malfunctions.
- Any repairs to the instrument must be performed by agencies authorized by Taiwan Advanced Nanotech Inc.
- Only use the original spare parts supplied by Taiwan Advanced Nanotech Inc on the instrument.
- If the equipment is used in a manner not specified by the manufacturer, the protection given by the instrument may be impaired or invalid.
- User and/or patient the need to report any serious incident that occurred in relation to the device to the manufacturer and to the competent authority of the Member State where the user and/or patient is established.

1. Introduction

About

Maelstrom Switch 8 is an automated nucleic acid platform designed for Flexible Applications. Specialized spin tips enable mixing efficiency of magnetic beads. With intuitive interface and compatible with most representative brands reagent kits. Maelstrom Switch 8 can boost molecular laboratory productivity by transforming routine operations into a walk-away solution.

Operation Principle

The Maelstrom Switch 8 uses magnetic rods to collect and transfer magnetic beads and spin tips to mix suspensions, which the spinning tips can mix the suspensions very well, and the extended magnetic rods can collect magnetic beads efficiently. Purified nucleic acids are obtained after cell lysis, nucleic acids absorption, washing and elution.

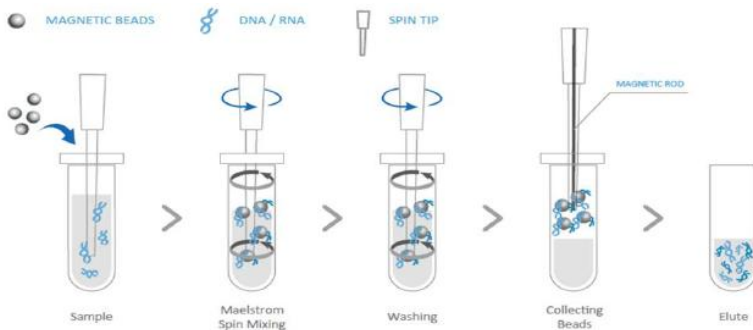

1. Introduction

Intended Purpose/Intended Use

The Maelstrom Switch 8 is intended for medical laboratory use by trained personnel in an automation environment. The instrument is intended for automated transfer and processing of magnetic particles in a microplate format, to extract and purify nucleic acids from samples. The purified nucleic acid can be used with any downstream application employing PCR-based qualitative, semi-quantitative and quantitative assays.

1. Introduction

Sample Type

Maelstrom Switch 8 automated nucleic acid extractor is not applicable for specimen collection. It was applicable with various types or brands of magnetic bead-based extraction kits, but not specific for TANBead Nucleic Acid Extraction kits. Please refer to the following for sample type and compatible reagent kits for reference.

Sample	Reagent kits		
Blood	61E series	611 series	621 series
cfDNA	622 series 61C series		
Virus	615 series 685 series 61G series	635 series 61H series 61G-SE series	665 series
Bactria	6BG series		6MB series
Tissue	6T2 series	6K2 series	
FFPE	61P series	62P series	
Stool Plant Fungi/ yeast Environment sample Food and feed Forensic	6SC series 613 series 61F series 6EM series 6GM series 6TF series	613 series	6K3 series
Plasmid	6PE series		

1. Introduction

Environmental Requirements

To avoid shortening the lifespan of the instrument, use Maelstrom Switch 8 in a location that meets the following criteria:

- Choose a location with good air circulation.
- Place Maelstrom Switch 8 on the table that can bear at least 20 kg.
- Do not use Maelstrom Switch 8 in a location where is with huge temperature and humidity variability.
- Operate condition:
Temperature: 10-40°C
Relative humidity: 40-80%
- Storage and transport condition:
Temperature: 5-50°C
Relative humidity: 20-85%
- Maximum operate altitude:
2000m

1. Introduction

Safety Instructions and Guidelines

- This device can be used with potentially biohazardous materials. Use appropriate personal protective equipment (gloves, safety goggles, lab coat, etc.) for handling and disposing of biohazardous materials.
- Under a normal condition, sound pressure level from Maelstrom Switch 8 does not exceed 80dB and does not cause a hazard. Please contact technical support for assistance in case of a higher sound pressure level.
- This device can be hazardous due to the use of chemical and biohazardous substances.
- Users should adhere to their institutional guidelines for the handling and disposal of all infectious substances used with this device.
- It is important to clean the device after every use. If samples or reagents have been spilled, clean the instrument immediately to avoid damage or contamination.
- This device is to use with the compatible spin tips. Using incompatible spin tips may cause poor extraction performance.
- Read this user manual completely prior to operating the device. Failure to read, understand, and follow the instructions in the manual may result in damage to the device, injury to laboratory and operating personnel or poor performance.

1. Introduction

- This instrument contains a button cell battery compliant with the European Union Battery Regulation (EU) 2023/1542. The battery meets chemical restriction limits, is CE-marked in accordance with the Regulation, and is subject to the EU take-back and recycling obligations.

Safety Requirements

- The device has passed the tests and conformed to the standards of IEC 61010-1:2010+A1:2016 (Edition 3.1) and EN 60101:2010+A1:2019, "Safety requirements for electrical equipment for measurement, control, and laboratory use - Part 1: General requirements".
- The device has passed the tests and conformed to the standards of IEC 61010-2-101:2018 with IEC 61010-1:2010 + A1:2016 and EN 61010-2-101:2017 with EN 61010-1:2010 + A1:2019, "Safety requirements for electrical equipment for measurement, control and laboratory use - Part 2-101: Particular requirements for in vitro diagnostic (IVD) medical equipment".

EMC Requirements

- The device has passed the tests and conformed to the standards of IEC 61326-1:2020 / EN IEC 61326-1:2021 & IEC 61326-2-6:2020 / EN IEC 61326-2-6:2021, "Electrical equipment for measurement, control and laboratory use - EMC requirements - Part 2-6: Particular requirements - In vitro diagnostic (IVD) medical equipment".

2. Instrument Overview

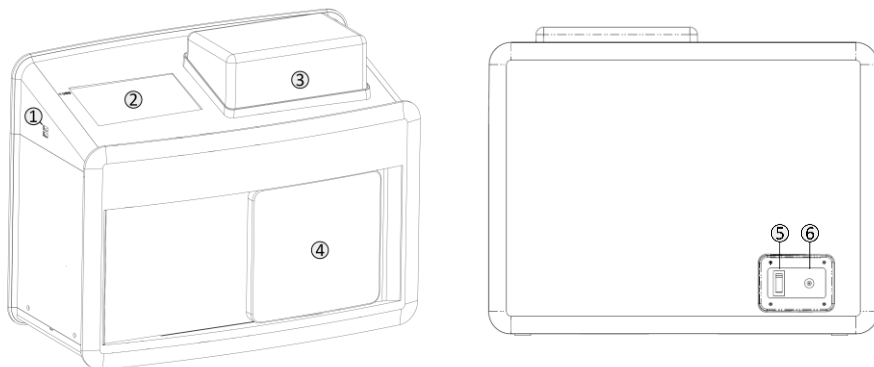

- ① USB port
- ② Touch screen
- ③ Top lid
- ④ Door lid
- ⑤ Power switch
- ⑥ DC Power inlet

2. Instrument Overview

ENGLISH

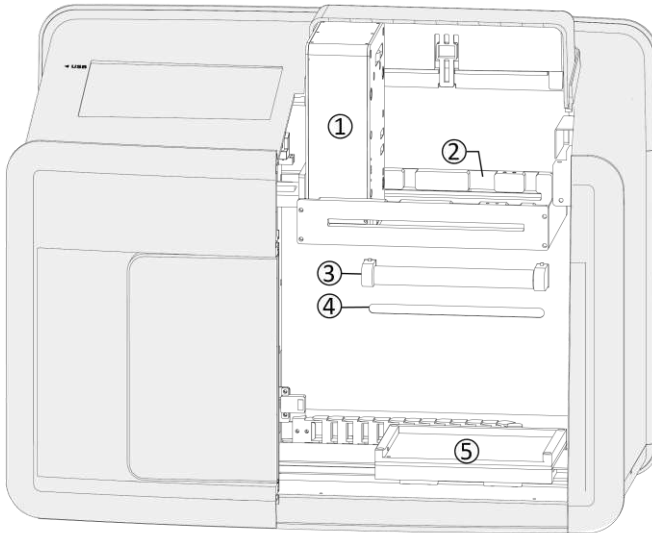

- ① Fixed motor module
- ② Guide rail
- ③ UV light
- ④ LED light
- ⑤ Loading position ; **Do not move the stage by hand.**

2. Instrument Overview

Packing List:

Following accessories may vary region-to-region.



Power cord

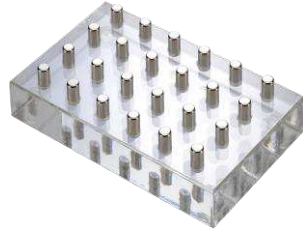

Magnetic separator









Power adapter

2. Instrument Overview

Compatible Gearbox Sets

(A) Large Magnetic Rod Gearbox Set for Leading breads reagents

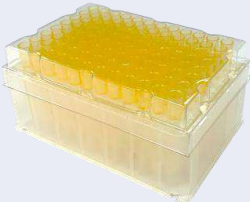
ENGLISH

Gearbox	Heating Plate	Consumable
<p>CH 4 Gearbox Ø7.5(A)</p> 	<p>24 Heating Plate F</p>  <p>Marked with "F" on the heating plate; compatible with Ø7.5 rods (A type).</p>	<p>24 Spin Tips (Ø7.5) Assembled Box</p> 
<p>CH 8 Gearbox Ø3.5(A)</p> 	<p>96 Heating Plate F</p>  <p>Marked with "F" on the heating plate; compatible with Ø3.5 rods (A type).</p>	<p>96 Spin Tips (Ø3.5) Assembled Box</p> 
<p>CH16 Gearbox Ø3.5(A)</p> 	<p>96 Heating Plate F</p>  <p>Marked with "F" on the heating plate; compatible with Ø3.5 rods (A type).</p>	

2. Instrument Overview

(B) Small Magnetic Rod Gearbox Set for TANBead Prefilled Reagents

Gearbox	Heating Plate
<p data-bbox="193 352 479 384">CH 4 Gearbox Ø4.2(B)</p> 	<p data-bbox="619 352 837 384">24 Heating Plate</p>  
<p data-bbox="193 699 479 730">CH 8 Gearbox Ø2.2(B)</p> 	<p data-bbox="619 699 837 730">96 Heating Plate</p>  
<p data-bbox="193 1045 479 1077">CH16 Gearbox Ø2.2(B)</p> 	

2. Instrument Overview

ENGLISH

Maelstrom Switch 8 uses specially designed for optimal processing. According to the magnetic rod types to applied with provided or compatible spin tip assembled box and deep well plates is a must. If applied with other types of consumables may damage the instrument and compromise the warranty. Contact us (service@tanbead.com) for further assistance if consumables other than suggested were needed.

(A) Large Magnetic Rod Gearbox Set for Leading breads reagents



24 Spin Tips (Ø7.5)
Assembled Box



96 Spin Tips (Ø3.5)
Assembled Box



24 Deep Well Plate, v-bottom F
Dimensions:
Length (L): 127.40 ±0.5 mm
Width (W): 85.48 ±0.5 mm
Height (H): 44.20 ±0.5 mm



96 Deep Well Plate, v-bottom F
Dimensions:
Length (L): 127.76 ±0.5 mm
Width (W): 85.48 ±0.5 mm
Height (H): 44.60 ±0.5 mm

2. Instrument Overview

(B) Small Magnetic Rod Gearbox Set for TANBead Prefilled Reagents



Spin Tips LV



96 Deep Well Plate



24 Spin Tip LV Holder



16 Base B



24 Deep Well Plate



6 Tube B



24 Deep Well Plate LV Base



Spin Tips Assembled Box

3. Instrument Specification

ENGLISH

Maelstrom Switch 8	SPECIFICATION					
Weight	N.W. 16.2 kg ; G.W. 23.0 kg					
Dimensions	Instrument: 524(W) x 265(D) x 412(H) mm Package: 638(W) x 426(D) x 568(H) mm					
Power Rating	I/P: 100~240V AC, 2.8A Max, 50/60Hz O/P: DC 24V, 8.3 A					
Spin Speed	500~3,000rpm					
Display	7" touch screen					
UV Light	UV-C					
Rod Type	(A) Large Magnetic Rod			(B) Small Magnetic Rod		
Channels	CH 4	CH 8	CH16	CH 4	CH 8	CH16
Gearbox						
Flux per run	1~4	1~8	1~16	1~4	1~8	1~16
Rod Size	Ø7.5(A)	Ø3.5(A)		Ø4.2(B)	Ø2.2(B)	
Magnetic Force (Gauss)	5,400	4,700		4,700	3,900	
Processing Volume (µL)	150~5,000 Max. 1500 rpm	50~1,200		100~9,000	50~1,600	
Application Reagents	Open to leading brands based on magnetic beads			TANBead: prefilled plate, prefilled single tube, bottle format		
Program	Customized program or assisted from TANBead			TANBead built-in programs		

4. Installation & Get Started

Please note that this instrument weight is around 20 kg, it is highly recommended to have 2 individuals or above to handle when taking it out from the box and be sure to work safety.

Step 1: Install the System

Take out the instrument from the box, 2 or more individuals is highly recommended.

Step 2:

Remove the cushions around and inside the instrument.



Always use and properly position EPE to protect the machine during transport.

Step 3:

Place the instrument on a flat table that bears over 20 kg.

Step 4: Install Gearbox

Refer to the applying consumables to install the Gearbox module refer by following procedures.

(A): Locate gearbox on guide rail



Do not "Power on" the instrument before install the gearbox. While manipulate the gearbox, please make sure the magnetic rods is safe from crushing to any parts.

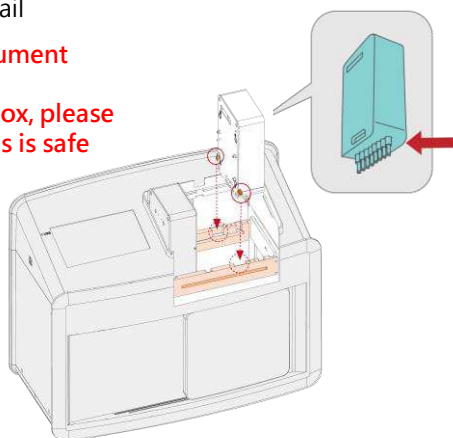

4. Installation & Get Started

(B) : Push gearbox to left side

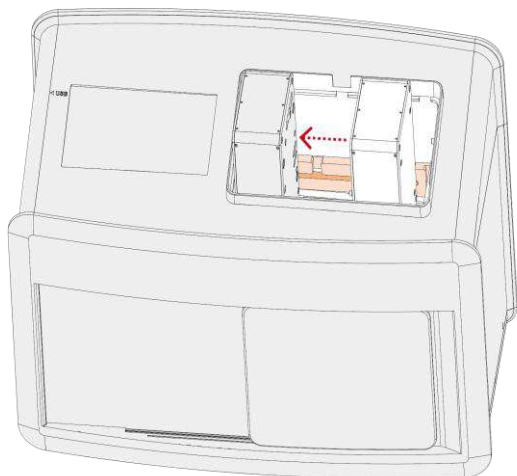

(C) : Make sure gearbox is attached firmly

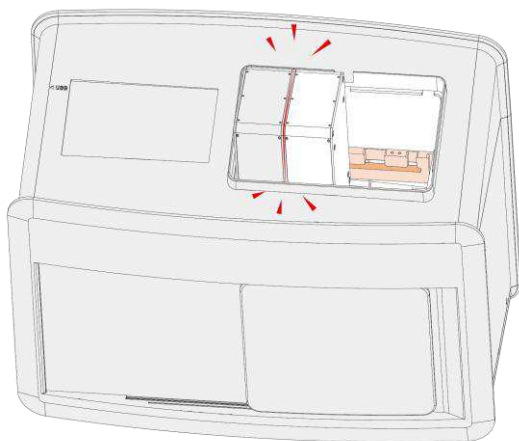

4. Installation & Get Started

(D) : Install the heating plate 96 or 24 wells accordingly



Keep heating plate horizontal during installation.

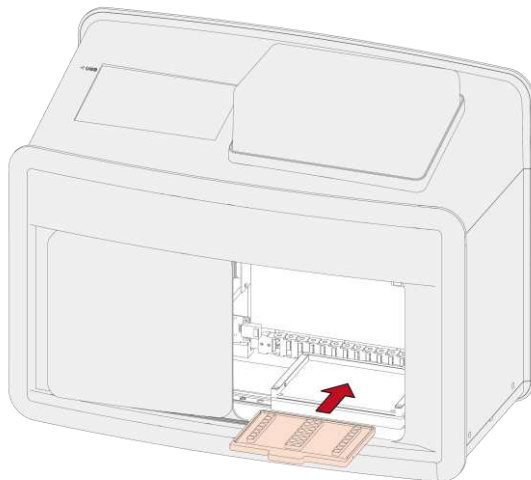

The heating plate surface may be hot during operation and change. Use cautiously to avoid risk of burns.

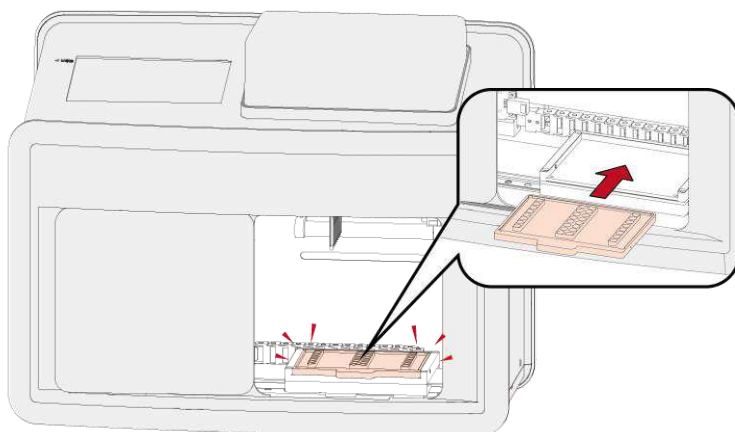

Note:

Heating plates marked with "F" support only Type A ($\text{Ø}7.5/\text{Ø}3.5$).

Plates without the "F" mark support only Type B ($\text{Ø}4.2/\text{Ø}2.2$).

4. Installation & Get Started

• Step 5: Apply Power Cord

- Apply with the power cord and adapter. Please note that this instrument is compatible with AC 100-240V power only. Using wrong power source will lead to malfunction or damage.

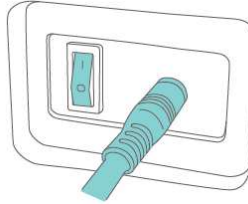

• Step 6: Power On

- Power on the instrument and it will perform initialization.

Warning: This product contains very strong permanent magnets. People wearing a pacemaker or metallic prostheses should not use this product. A pacemaker or prostheses may be affected or damage if it comes in close contact with a strong magnetic field.

• Step 7: Select Rod Type

- Refer to the label on top of the Gearbox to select the correct model. Then, tap "Yes" to confirm and proceed.

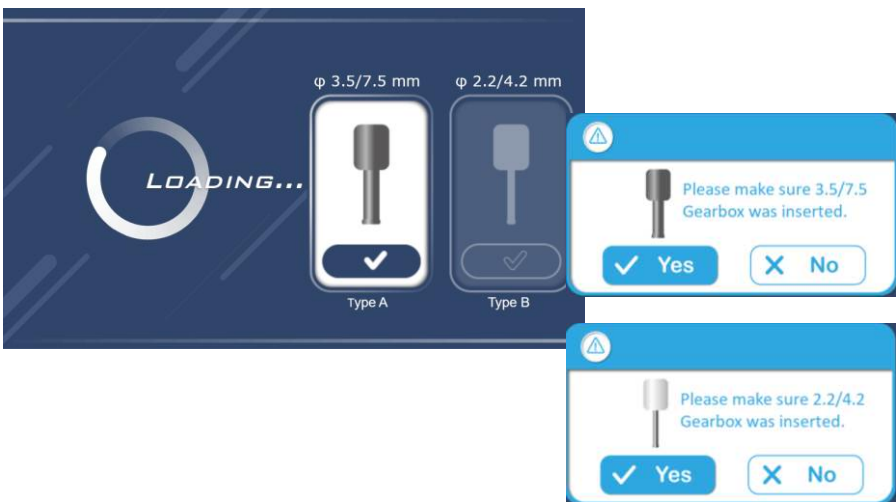

4. Installation & Get Started

- **Step 8: Enter user code**
- Refer to the next section for software operation instructions. After the system starts up, log in using the user code "222" for Supervisor Mode or "333" for Operator Mode.

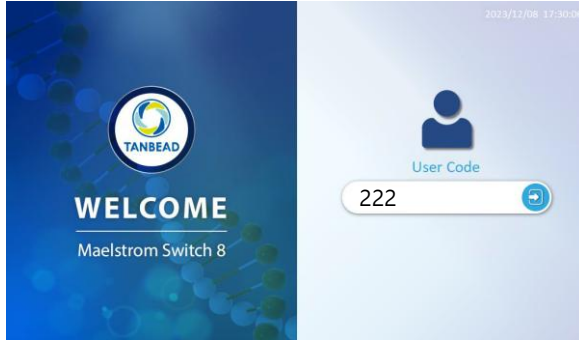

- According to the entered user code, the display on the main menu will be different as followed.



User code: 222

User code: 333



4. Installation & Get Started

- **Step 9: Edit Program** (for leading brands reagents)
- Refer to **Section 5.** to “Edit” the protocols for your reaction kits.

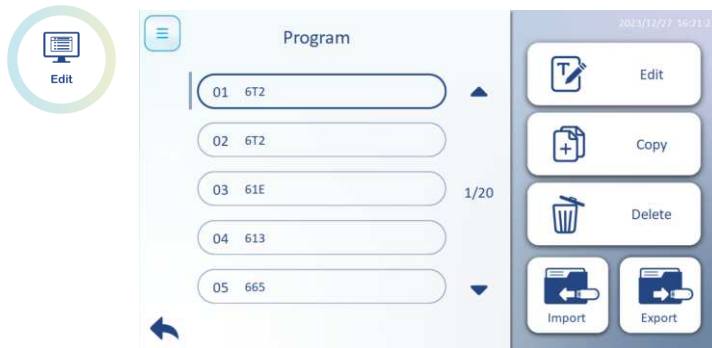

- **Step 10: Run Program**
- Tap “Run” and select the appropriate program to start the extraction. Then, press “▶” to proceed.

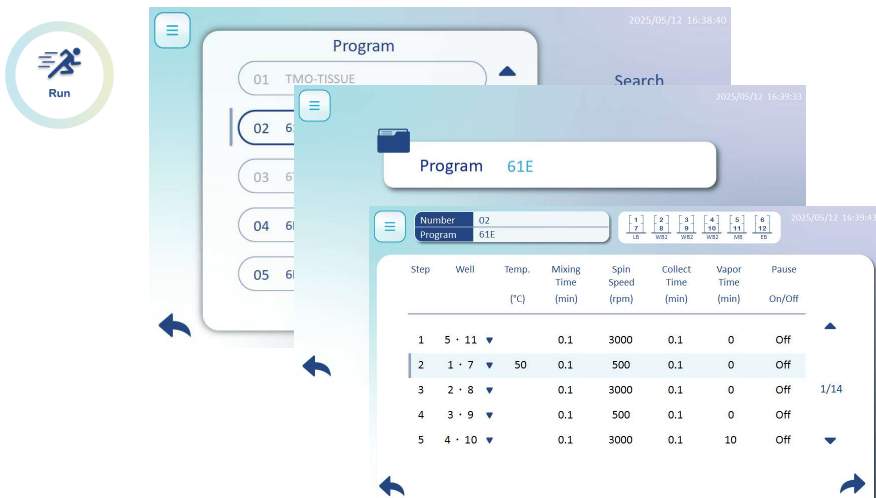

4. Installation & Get Started

- Select with "L" for left part of plate or "R" for the right. And press on "➡" to proceed. Refer to the container type to choose "Auto-plate" or "Auto-Tube" and click on "➡" to Start the run.

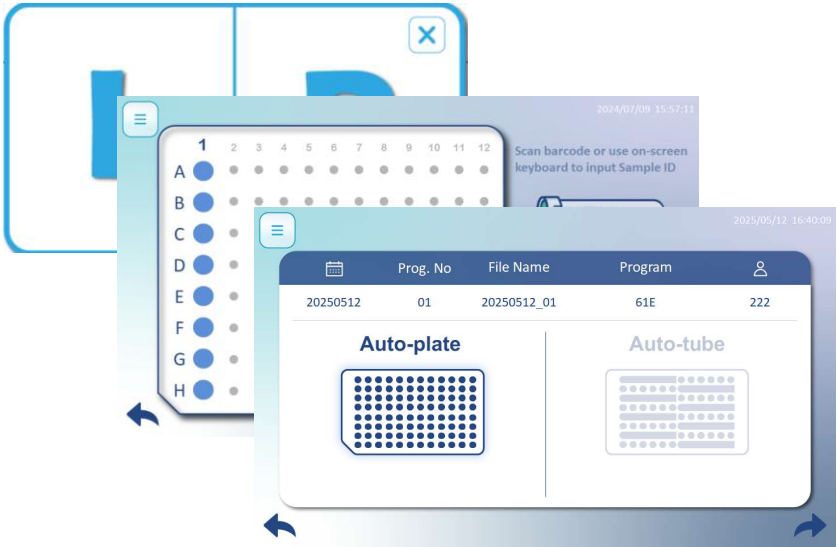

4. Installation & Get Started

- After placing the spin tip assembled box, tap “Mount” to pick up the tips in the selected lane.

Note: This applies only to the 8-channel gearbox. To ensure correct operation, use the matching left or right spin tip box when extracting samples from the corresponding side of the well plate.

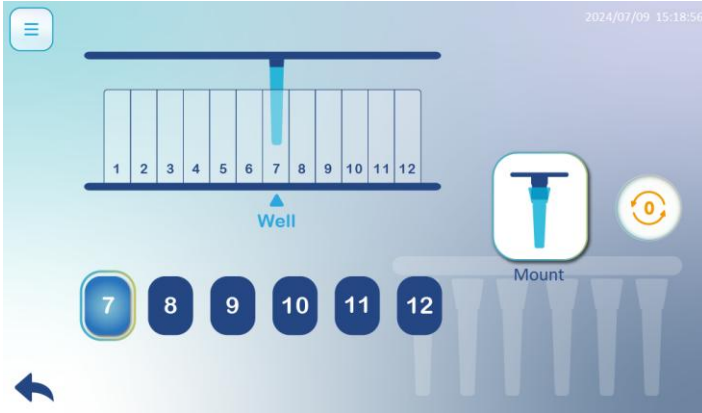

- After picking up the spin tips, a warning message will appear. Ensure that the prepared reaction plate has been placed into the chamber, then click “Yes” to proceed.

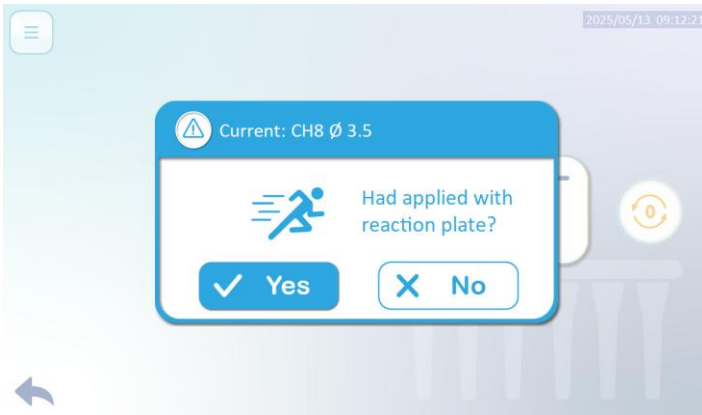

4. Installation & Get Started

- After heating up, the program will begin automatically.

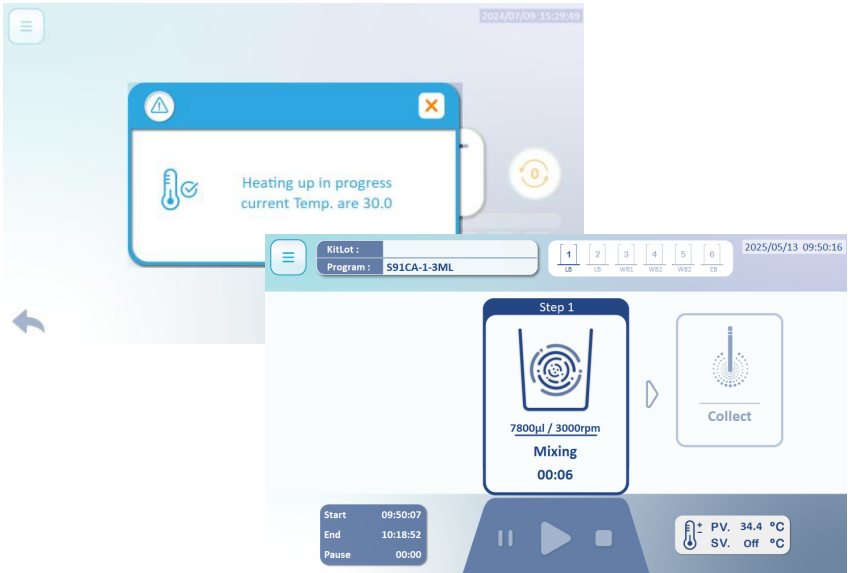

- After the program is completed, press "Report" to review the procedure details. When you close the report, a prompt window will appear.

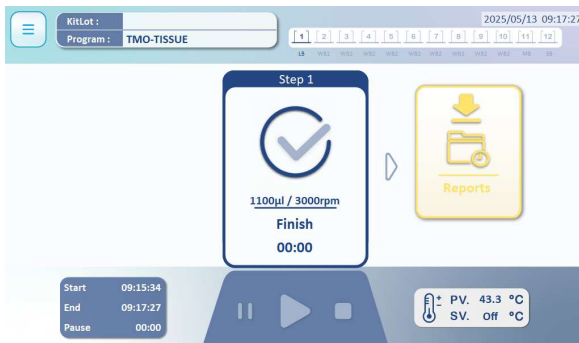

4. Installation & Get Started

- Select the desired lane to “Eject” the spin tip before returning to the main menu.

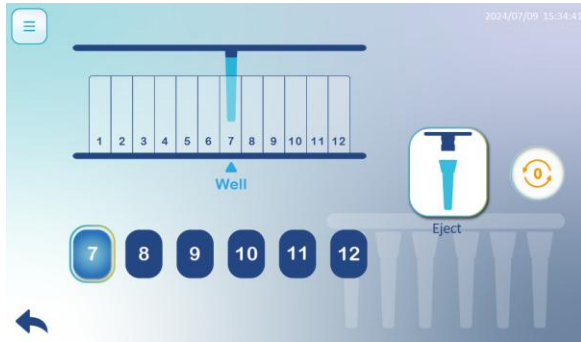

5. Software Applications

Start



After powering on the instrument, please allow a few seconds for the system to initialize. Refer to the label on top of the gearbox to select the correct size. Confirm your selection by tapping "Yes" to proceed.

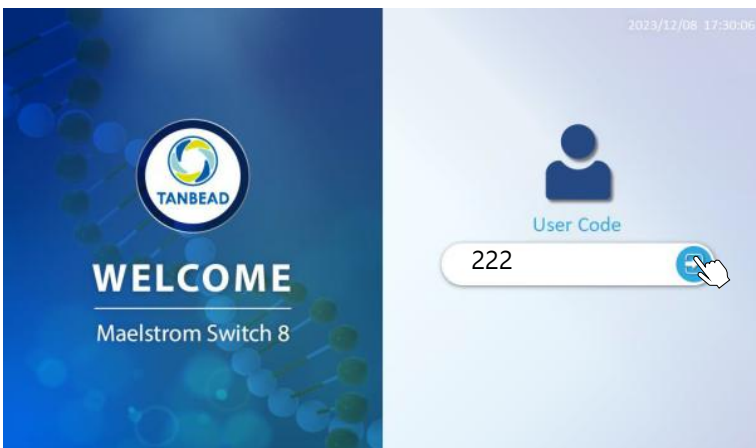

Enter "222" user code for Supervisor mode or "333" user code for Operator mode to access the system. In case of forgotten User Code, please contact local dealers or Taiwan Advanced Nanotech Inc. for assistance.

5. Software Applications

ENGLISH

- After entering the home screen, the system will automatically detect the type of gearbox and display the corresponding user interface as shown below. The functions of each icon will also vary depending on the detected gearbox type.

CH 4 Gearbox



CH 8 Gearbox



CH16 Gearbox



5. Software Applications

General functions:

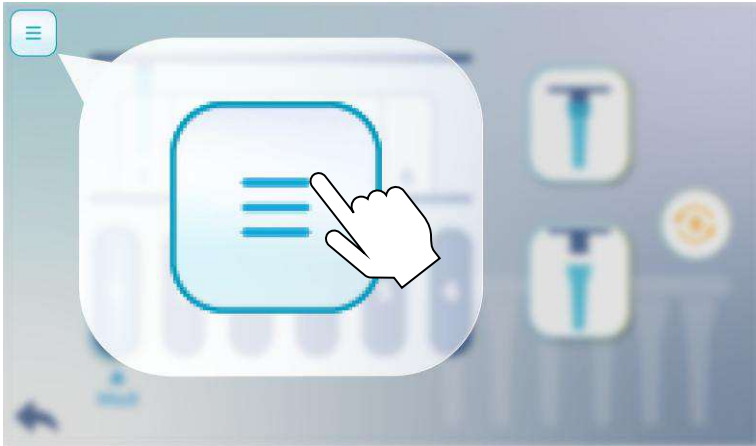

Press Toolbar to use following function.



- ① Back to Home Screen
- ② Turn on/off LED
- ③ Get the version information
- ④ Update software and firmware

5. Software Applications

The “Home Screen” on the Maelstrom Switch 8 provides access to the following functions. The displayed interface will vary depending on the type of gearbox in use.

Home Screen (CH 8 Gearbox as Example)



- ① Change User
- ② Current Temperature
- ③ Current Gearbox type

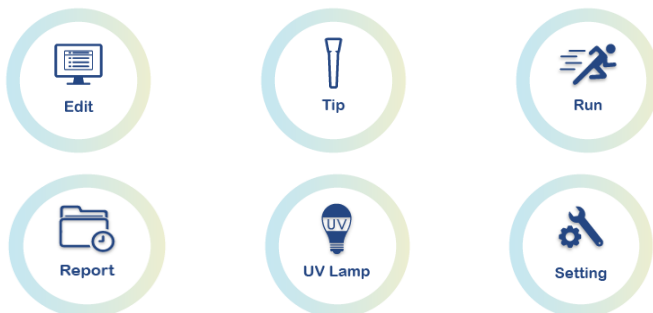

- **Edit:** Edit protocols.
- **Tip:** Eject tip(s).
- **Run:** Enter to “Run” a protocol.
- **Report:** Management of history data.
- **UV Lamp:** Switch the UV lamp on/off.
- **Setting:** Adjust the parameter of the transfer platform.

5. Software Applications



Edit: Edit protocols.

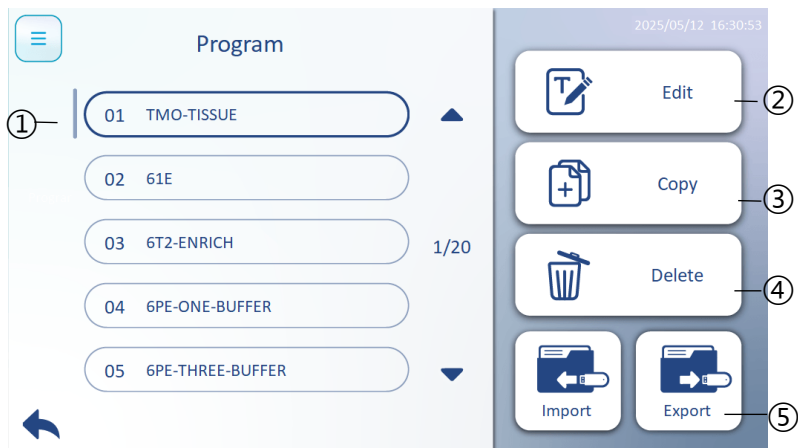

Tap to enter the “Edit” function, where you can modify existing programs or create custom protocols tailored to specific reagent kits. When using different gearboxes, separate programs should be created for each configuration.

- ① **Program:** List of all programs.
- ② **Edit:** Enter the selected program number to modify the protocols.
- ③ **Copy:** Copy the selected program number to the desired program number.
- ④ **Delete:** Tap to delete the selected program number
- ⑤ **Import/Export:** Use a USB drive to transfer programs into or out of the system.

5. Software Applications



Edit the existing programs.



Edit the selected program.

CH 8 Gearbox as example for instruction:

2025/05/13 10:02:10

① Number 02

② Program 61E

③ Heating (°C) 45

Well	Name	Volume(μl)	Action
1 • 7	LB	1100	Rev. U/D
2 • 8	WB1	800	For.
3 • 9	WB2	800	For.
4 • 10	WB2	800	For.
5 • 11	MB	800	For.
6 • 12	EB	100	For.

④

⑤

2025/05/12 16:33:05

Number 01

Program TMO-TISSUE

Heating (°C) 45

Well	Name	Volume(μl)	Action
7	WB2	1100	For.
8	WB2	800	Rev.
9	WB2	800	For. U/D
10	WB2	800	Rev. U/D
11	MB	800	For. U/D
12	EB	100	Rev. U/D

- ① **Number:** Program number for saving
- ② **Program:** Name of the protocol.
- ③ **Heating:** Activate the pre-heating function with setting temperature.
- ④ **Protocols:** Preview of the protocols.
- ⑤ **"Previous"** to go back or **"Next"** steps to detail protocol setting.

5. Software Applications



Edit the existing programs.



Edit the selected program.

Preview of protocols

① ② ③

Well	Name	Volume(μ l)	Action
1 • 7	LB	900	Foc
2 • 8	WB1	800	Foc
3 • 9	MB	800	Foc
4 • 10	WB2	800	Foc
5 • 11	WB2	800	Foc
6 • 12	EB	130	Foc

Preview of the protocols and enter with related settings.

- ① **Name:** Tap to select the buffer name of each step.
- ② **Volume:** Tap to enter the volume of each sample well.
- ③ **Action:** Tap to select different spinning mode with "Reverse", "Forward", "Reverse with up and down mixing", and "Forward with up and down mixing".

① ② ③

Well	Name	Volume(μ l)	Action
1 • 7	LB	900	Foc
2 • 8	WB1	800	Foc
3 • 9	WB2	800	Foc
4 • 10	WB3	800	Foc
5 • 11	EB	800	Foc
6 • 12	EB	130	Foc

②

50 ~ 1600

7 8 9
4 5 6
1 2 3
0 . OK

Well	Name	Volume(μ l)	Action
1 • 7	LB	900	Foc
2 • 8	WB1	800	Foc Rev. Foc U/D Rev. U/D
3 • 9	MB	800	Foc
4 • 10	WB2	800	Foc
5 • 11	WB2	800	Foc
6 • 12	EB	130	Foc

5. Software Applications



Edit the selected program.



Edit: Edit protocols.

Detail protocol setting:

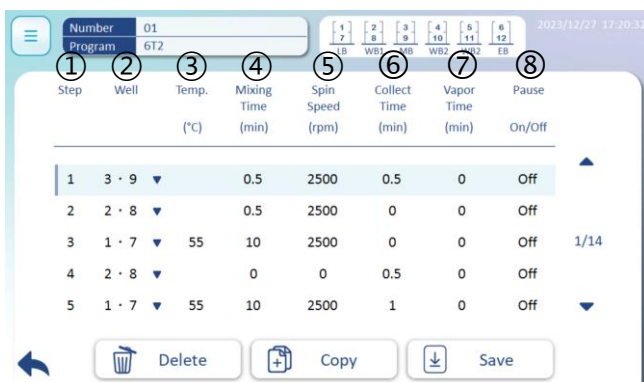

Preview the protocol, and tap on the displayed values to enter related settings as shown below. Use "Delete" to remove steps, "Copy" to duplicate steps, and "Save" to store the program settings.

Note: When editing protocols, ensure that magnetic beads and ejected spin tips are not placed in the same well.

- ① **Step:** The order of the gearbox's motion.
- ② **Well:** Processing well of each step.(May different by gearbox types.)
- ③ **Temp.:** Heating On/Off and temperature setting of the step.
- ④ **Mixing Time:** mixing time length setting of the step
- ⑤ **Spin Speed:** speed setting of the stirring
- ⑥ **Collect Time:** time setting for magnetic rod to collect the beads
- ⑦ **Vapor Time:** time setting for the evaporation of collected beads
- ⑧ **Pause:** ON or OFF the pause function to temperately stop the procedure.

5. Software Applications



Edit the existing programs.



Copy: Copy the selected program number to the desired position.

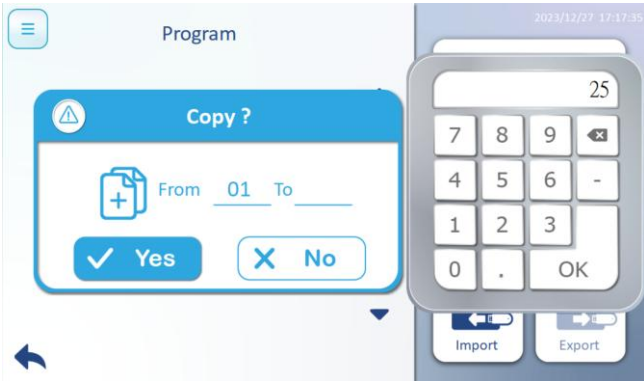

Delete: Delete the selected program number.



Import/Export: Programs can be imported or exported into CSV format through a USB drive. File format is shown as below.

	A	B	C	D	E	F	G	H
1	Temp1	Temp2						
2	40	40						
3								
4	Well	Name	Volume	Action	Mixing	Collect		
5	1	LB	900	Rev. U/D	Low	Low		
6	2	WB1	800	For.	Low	Low		
7	3	WB2	800	For.	Low	Low		
8	4	WB2	800	For.	Low	Low		
9	5	MB	800	For.	Low	Low		
10	6	EB	150	For.	Low	Low		
11								
12								
13	Step	Well	Temp	Mix_time	Mix_spee	Collect_ti	Vapor_tin	Pause
14	1	5		0	3000	0.1	0	Off
15	2	1	65	6	3000	0.5	0	Off
16	3	2		0.5	3000	0.1	0	Off
17	4	3		1	3000	0.2	0	Off
18	5	4		0.5	3000	0.2	7	Off
19	6	6	45	3	3000	0.5	0	Off
20	7	3		0.1	3000	0	0	Off

Note: Do not alter the internal format of the CSV file. Modifying the position or arrangement of data may lead to processing errors.

5. Software Applications



Eject Tip(s)

The display layout may vary depending on the gearbox used; however, the function icons remain the same. When ejecting the spin tips, it is recommended to use an empty reaction plate.



Please use correct consumables that is compatible with the installed gearbox.

CH 8 Gearbox

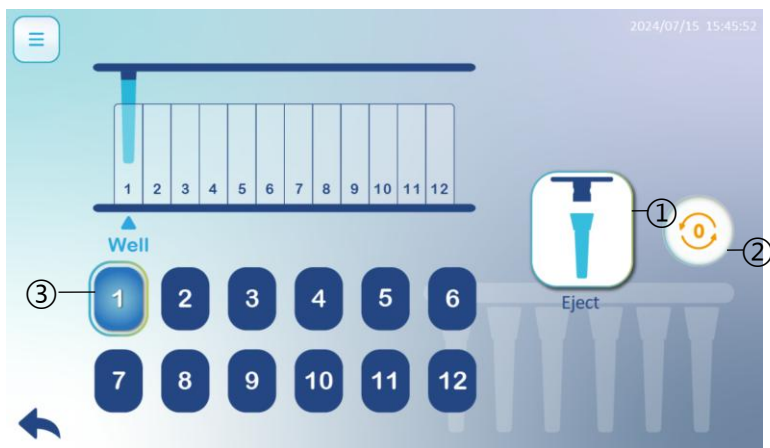

Caution: Before starting a run, ensure that no spin tips remain on the gearbox or inside the chamber.

Eject Tip : Press the icon to leave tips.

① Origin: Press the icon to initialize instrument.

② Well : Tap the icon 1~12. to leave tips in different positions.

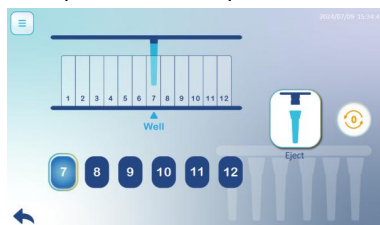

5. Software Applications



Eject Tip(s)



Please use correct consumables that is compatible with the installed gearbox.

CH 4 Gearbox

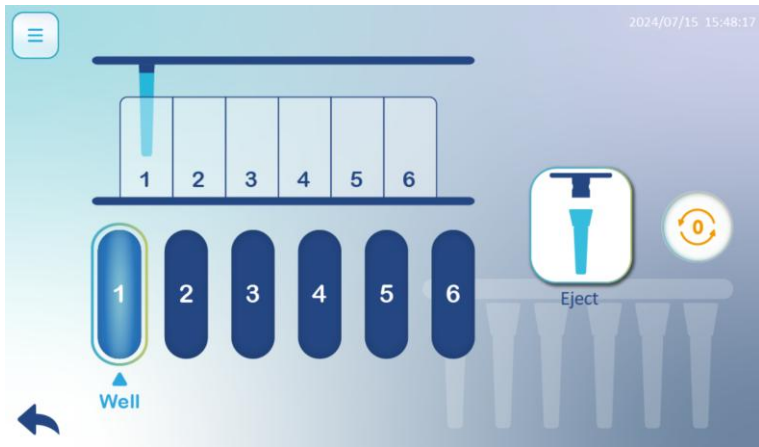

CH16 Gearbox

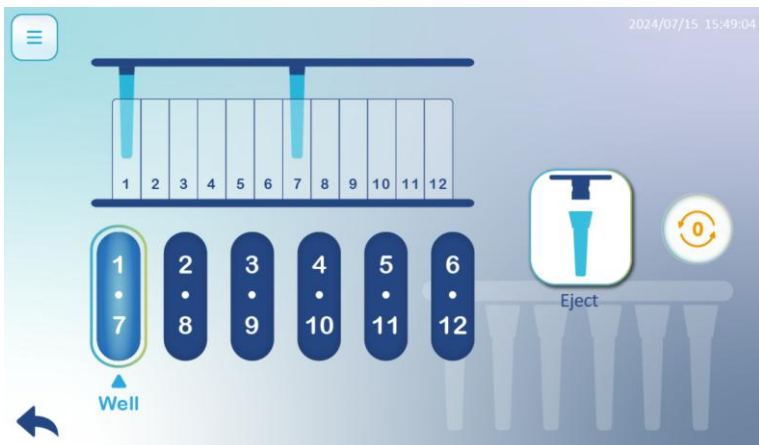

5. Software Applications



Run a protocol

Double-tap the selected program to start.



The Switch 8 can store up to 100 programs, providing ample flexibility. Select the program that corresponds to your reagent kit. If needed, use the Search box to enter keywords and locate the desired program.

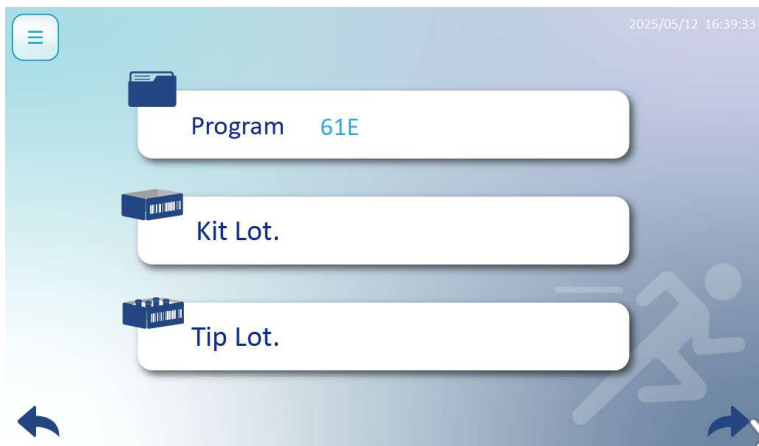

Enter the kit lot number and tip lot number for tracking purposes. Press "➡" to proceed to the next page.

5. Software Applications



Run a protocol

Review with the setting program by scrolling up or down. And press on "➡" to proceed.

Step	Well	Temp. (°C)	Mixing Time (min)	Spin Speed (rpm)	Collect Time (min)	Vapor Time (min)	Pause On/Off
1	5 · 11		0.1	3000	0.1	0	Off
2	1 · 7	50	0.1	500	0.1	0	Off
3	2 · 8		0.1	3000	0.1	0	Off
4	3 · 9		0.1	500	0.1	0	Off
5	4 · 10		0.1	3000	0.1	10	Off

For the CH8 gearbox running a 6-step program, users can choose to operate on either the "Left" or "Right" region of the deep well plate. However, this option is not available for other types of gearboxes or for 12-step programs.

Step	Well	Temp.	Mixing	Spin	Collect	Vapor	Pause On/Off
1	5 · 11						Off
2	1 · 7						Off
3	2 · 8						Off
4	3 · 9						Off
5	4 · 10		0.1	3000	0.1	10	Off

Choose a region "Left" or "Right" to run a protocol. Choose "Left" means to process from Lane 1 to Lane 6, and "Right" means from Lane 7 to Lane 12.

5. Software Applications



Run a protocol

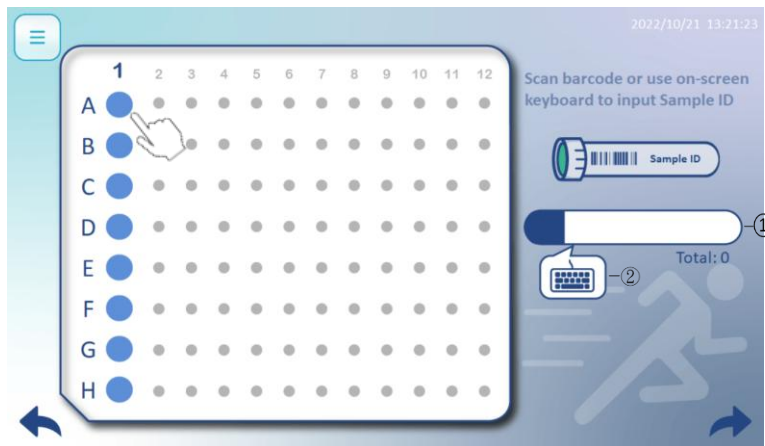

Press a circle(A1~H1) to input sample ID by using 1-D barcode ①barcode or ②manual type in.

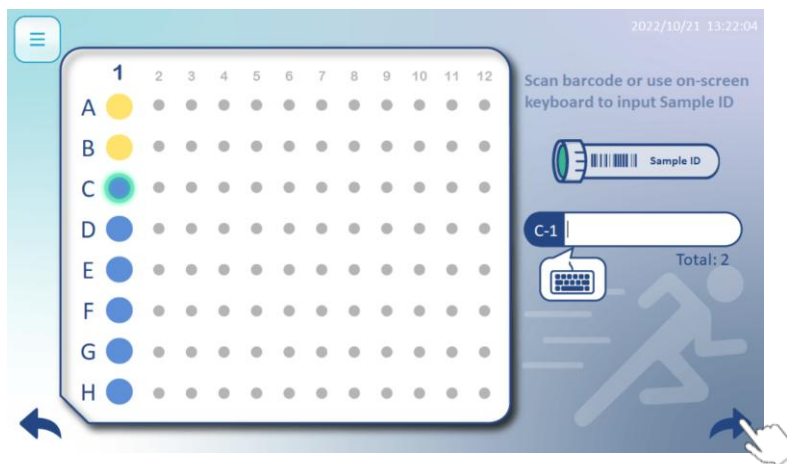

The circle indicator turns yellow upon successful entry of a sample ID, and the system will automatically advance to the next sample position (e.g., A1 → B1, B1 → C1, etc.). Press "➡" to proceed to the next page.

NOTICE:

Be careful not to touch adjacent buttons or areas while entering data to avoid input errors.

5. Software Applications



Run a protocol

According to the applying plate format, choose "Auto-Plate" or "Auto-Tube" to proceed.

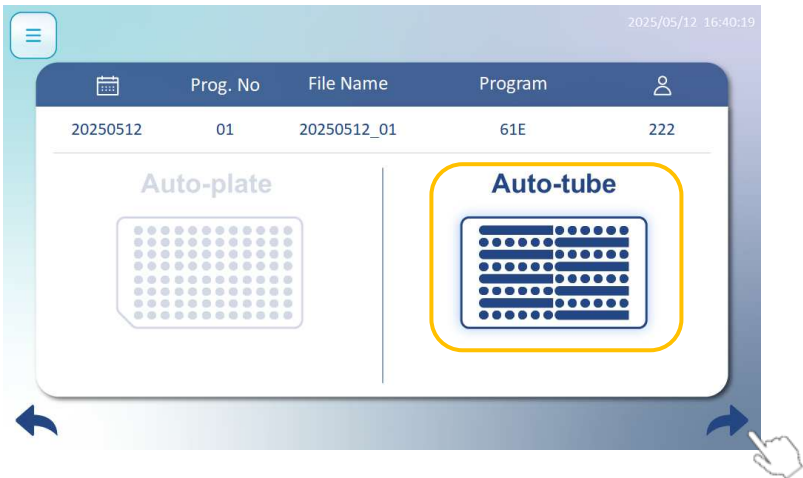
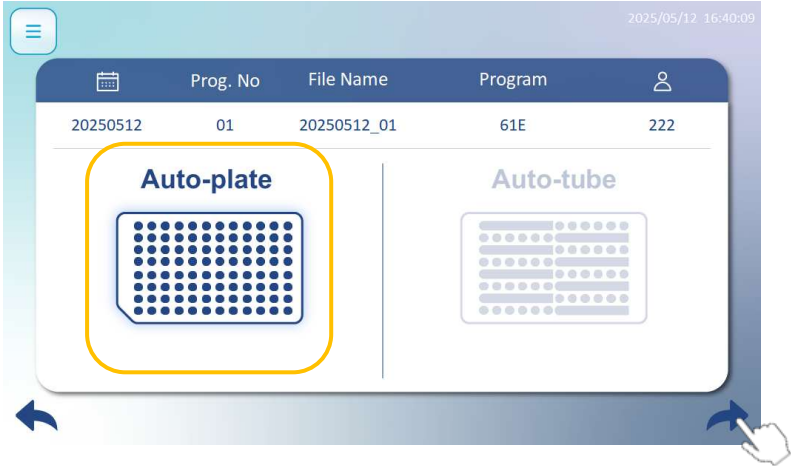



Please verify that the information above such as the date, program, and file name is correct. Press the " → " icon to execute the program, or tap the " ← " icon to return to the previous page.

5. Software Applications

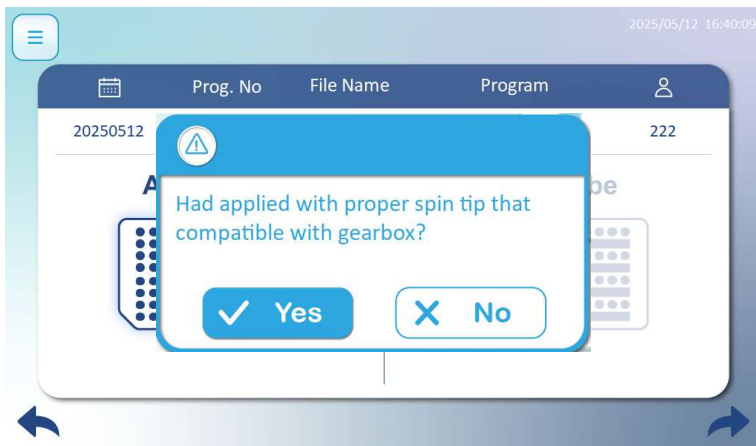

Run a protocol



After pressing the “” icon, a warning window will appear. Ensure that the correct spin tip assembled box is loaded into the system, then click “Yes” to proceed or “No” to return to the previous page.

Mount Tip

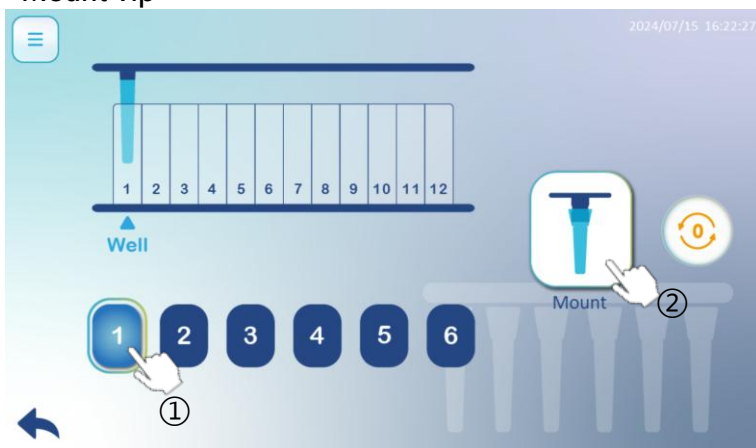

Place the spin tip assembled box onto the heating plate inside the Switch 8.

- ① Select the desired lane.
- ② Press “Mount” to pick up the spin tips

5. Software Applications



Run a protocol

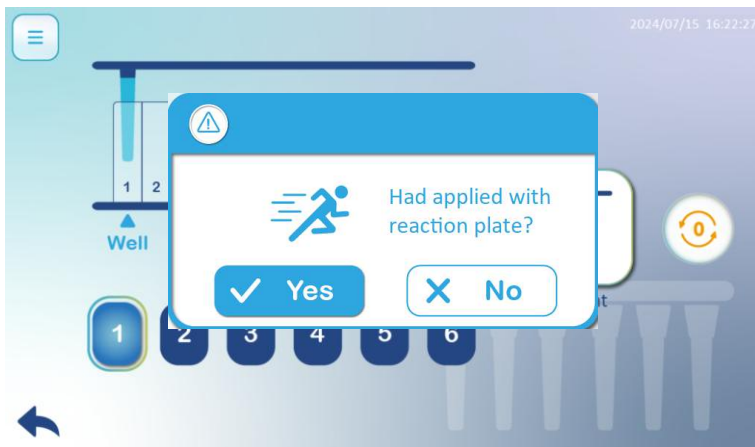

After picking up the spin tips, be sure to replace the spin tip assembled box with the prepared reaction plate. Click "Yes" to proceed, or "No" if the plate is not yet ready.

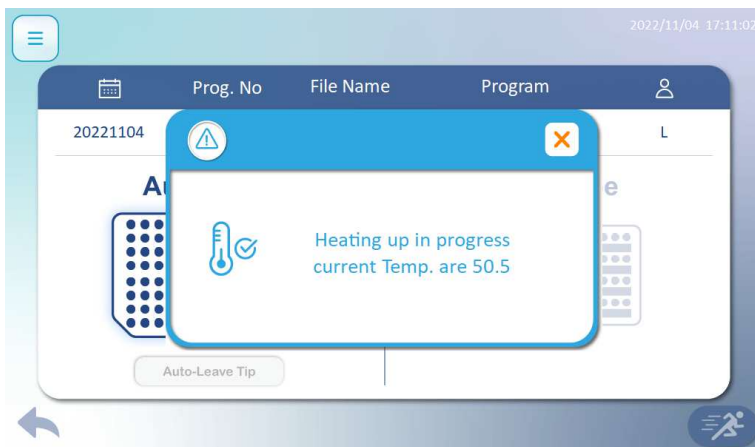

Program will start when the temperature reaches the set value.

5. Software Applications



Run a protocol

Running Status:

Start	End	Pause
09:50:07	10:18:52	00:00

PV. 34.4 °C
SV. Off °C

Familiarizing yourself with the following symbols is highly recommended, as they help you understand the protocol status:

- ① **Current Step** – Indicates the step currently being executed.
- ② **Start Time, Estimated End Time, Pause Time** – Displays the timing information related to the run.
- ③ **PV / SV** – PV refers to the actual temperature, while SV is the set temperature for the current step



Pause : Pause a protocol that is in progress



Resume : Continue a pause protocol



Stop : Stop a protocol that is in progress

5. Software Applications



Run a protocol



Mix :This step is to mix beads and reagents



Collection: This step is used to collect magnetic beads from the wells of the plate. If "Pause" or "Stop" is pressed during this step, the Maelstrom Switch 8 will not respond immediately, it will first complete the bead collection process before pausing or stopping.



Vapor : This step dries the magnetic beads above a well or tube.



Completion : A buzzer will sound when the protocol has finished.



Pause : Pause a protocol

1	2	3	4	5	6
7	8	9	10	11	12
LB	WB1	WB2	MB	WB3	EB



Well 1 to 12, number of well and name of buffer varies from kits to kits.

5. Software Applications



Run a protocol

ENGLISH

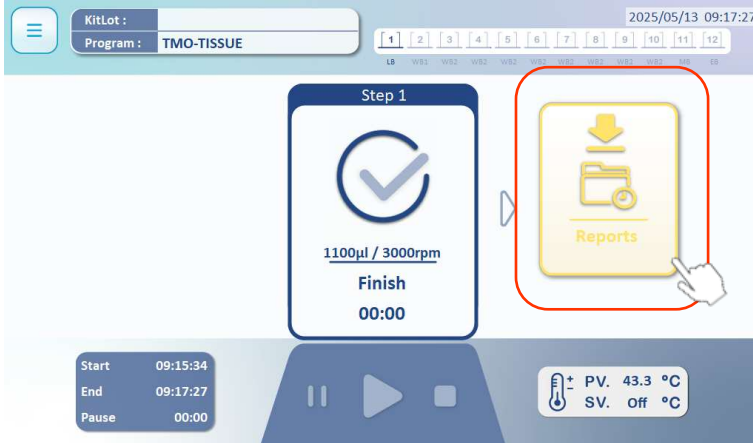

After the program is completed, press "Report" to review the results.

To complete the entire procedure, the spin tips must be ejected. Select a lane for ejection that is not the same as the one containing magnetic beads.

Notice:

Do not leave magnetic beads and ejected spin tips in the same lane.



5. Software Applications



Reports : Manage history data.

Tap the checkbox(es) to delete data or to export data to a USB drive.

2022/10/12 16:19:12

	File Name	Kit Lot.		Error	
<input checked="" type="checkbox"/>	20220714	20220714_01	L	00000000	▲
<input checked="" type="checkbox"/>	20220706	20220706_01	L	00000000	
<input type="checkbox"/>	20220706	20220706_02	L	00000000	1/25
<input type="checkbox"/>	20220705	20220705_01	L	00000000	▼

Page 1/2
100 records per page switch

Delete Export to USB

5. Software Applications



UV Lamp : Switch the UV lamp on/off.



Set UV time, then press the light bulb to start.



**Please close the door before turning on the UV light.
A recommended operating time is at least 5 minutes.**

5. Software Applications



Setting: Basic Parameters can be set through setting function, including User Management, Language, and Time.



- ① **User Management:** Set operator access levels through this function.
- ② **Language:** Change the user interface language.
- ③ **Time:** Adjust the system time settings for the instrument.

5. Software Applications

12-Step Program

When using the CH8 gearbox, a special program called the “12-step program” is available, allowing users to freely customize processes across all 12 lanes of the reaction plate.

In the “Edit” section (see Page 34), the program list will display two types of programs that users can modify.



When editing a 12-step program, the interface will appear as shown in the figure below on the left.



5. Software Applications

After entering the editing interface, in the 12-step program (A), the “Well” lane can be freely selected from lanes 1 to 12.

However, in the 6-step program (B), the lanes are paired, lane 1 is linked with lane 7, lane 2 with lane 8, lane 3 with lane 9, and so on.

(A) 12-Steps Program

Step	Well	Temp. (°C)	Mixing Time (min)	Spin Speed (rpm)	Collect Time (min)	Vapor Time (min)	Pause On/Off
1	2		1	3000	0.5	0	Off
2	2		0.1	2000	0	0	Off
3	3		0.1	500	0	0	Off
4	4		0.1	500	0	0	Off
5	5		0.1	500	0	0	Off

(B) 06-Steps Program

Step	Well	Temp. (°C)	Mixing Time (min)	Spin Speed (rpm)	Collect Time (min)	Vapor Time (min)	Pause On/Off
1	5 · 11		0.1	3000	0.1	0	Off
2	1 · 7		0.1	500	0.1	0	Off
3	2 · 8		0.1	3000	0.1	0	Off
4	3 · 9		0.1	500	0.1	0	Off
5	4 · 10		0.1	3000	0.1	10	Off

6. Technical Support

If you have any questions, please contact the authorized distributor nearest to your location. Taiwan Advance Nanotech Inc. provides post-sale services call number at +886-3-3167568 or via email: service@tanbead.com for assistance.

Please provide this instrument serial number when you talk to our technician, that will solve the problems efficiently and answer your questions more precisely.

7. Cleaning and Maintenance

- Clean the device after every use. When users detect samples or reagents have been spilled, clean the device immediately to avoid damage or contamination.
- Wear gloves and appropriate personal protective equipment. If the device is used with biohazardous materials, dispose of any cleaning materials used in accordance with your institutional guidelines.
- The device may go through a run with the magnetic rods unprotected. If this happens, the magnetic rod needs to be cleaned immediately.
- To clean the magnetic rods, wipe with a soft cloth dampened with pure water. Do not use alcohol solvent.
- If the contaminated magnetic rods become rusted or cannot be cleaned, please contact the authorized distributor nearest to your location or TANBead (service@tanbead.com) for technical assistance.

8. Disposal

The decision whether to dispose of a potentially contaminated device is usually made by the owner in consultation with appropriate federal, state, and local authorities. In determining which devices should be discarded, the owner must assess each product's current condition and potential safety risks.

9. Patent

Patent List

USA	US09616398B2
EU	EP2937136
Canada	CA2862946
Japan	JP6151735B2
Korea	KR101696517B1
China	CN104971638B
Taiwan	TWI526245B
WIPO	WO2016127292

10. About Manufacturer



- **Manufacturer** : Taiwan Advanced Nanotech Inc.
- **Legal Manufacturer** : 6F., No. 188, Wenhe Rd., Guishan Dist., Taoyuan City 333, Taiwan (R.O.C)
- **Production Site** : 4F., No. 188, Wenhe Rd., Guishan Dist., Taoyuan City 333, Taiwan (R.O.C)
- **Manufacturer Tel** : +886-3-3167568

11. Advisory Notices

The Company may issue advisory notices from time to time (including safety alerts, reinforced instructions for use, or corrective recommendations) to ensure continued safe and effective use of the product.

- For the latest advisory notices, please contact Customer Service service@tanbead.com
- The Company will retain records of distribution and acknowledgment of issued advisory notices and will notify distributors / end users as appropriate.

12. TANBead Instrument Warranty Policy

This warranty sheet covers the Nucleic Acid Extractors manufactured by Taiwan Advanced Nanotech Inc. (Hereinafter referred to as TANBead).

TANBead warrants that under normal use conditions, this product will not have any material or manufacturing defects for one year from the date of purchase. If any defect is found within the warranty period, TANBead will repair or replace the product free of charge.

This warranty policy does not apply to the following situations:

- The product is damaged due to improper use, operation, storage, maintenance, abuse, or transportation of the products.
- The product is damaged due to accident, disaster, natural phenomenon, or other force majeure factors.
- The product is modified, disassembled, reassembled, or repaired by unauthorized personnel.
- The product exceeds its expiration date or is not used according to the instructions.
- Damage or loss caused by factors beyond TANBead's control, such as sample quality, experimental conditions, or user error.

To claim the warranty, please contact our customer service department with the following information:

- Proof of purchase (invoice, receipt, etc.)
- Product name (model) and serial number
- Description of the problem and evidence of defect or malfunction (photos, test results, etc.)

We will provide you with instructions on how to return the products. Please do not return the products without our authorization. TANBead will bear the shipping cost of returning the product, but not any other expenses or losses.

This warranty policy is your only remedy and replaces any other express or implied warranties or conditions. In no event shall TANBead be liable for any indirect, special, incidental, or consequential damages, including but not limited to loss of profits, business interruption, data loss or other commercial losses.

We appreciate your business and hope that you are satisfied with our products. If you have any questions or concerns, please feel free to contact us at any time. Thank you for choosing TANBead! If you have any questions about our warranty services, please email to service@tanbead.com

To register your TANBead instrument for more technical support and services, please sign up an official membership of TANBead.





台灣圓點通量置換式核酸自動萃取
儀(未滅菌)

039.M17RU.X02

Maelstrom Switch 8

使用手冊

目錄

1.	簡介	64
2.	儀器概述.....	70
3.	儀器規格.....	77
4.	安裝與啟動.....	78
5.	軟體應用.....	88
6.	技術支援.....	113
7.	清潔保養須知.....	114
8.	儀器回收.....	114
9.	專利資訊.....	115
10.	製造業者及醫療器材商資訊.....	115
11.	重要通告資訊.....	115
12.	TANBead 儀器保固政策.....	116

關於儀器

儀器、使用說明書和其他包裝材料上的標籤可能包含以下符號：



型號



序號



製造商



製造日期



注意未滅菌



注意生物危害



注意高溫



注意



廢棄物電子電機設備指令



溫度限制



保持乾燥



遠離陽光



生物危害



濕度限制



使用說明書

關於儀器

警告

- 請使用符合銷售國家標準指定之電源線。如有任何疑問，請聯繫當地經銷商以獲得協助。
- Maelstrom Switch 8 的工作電壓範圍為 100 至 240 伏特。
- 請勿使用損壞的電源線或鬆動的電源插座。
- 拔除電源時，請握住插頭本體，切勿拉扯電源線。
- 執行清潔保養前，請務必關閉電源並拔除插頭。
- 請勿將任何液體倒在儀器上。
- 請勿在儀器上方放置任何裝有液體的容器，以免引發火災、觸電或導致儀器故障。
- 若有雷擊可能，請勿觸碰插頭或電源線，否則可能導致觸電。
- 使用中若聽見雷聲或懷疑雷雨將至，請立即關閉電源並拔除插頭，否則可能導致火災或儀器故障。

關於儀器

注意事項

- 未經製造商許可，切勿擅自改裝本儀器。否則可能導致火災或觸電。
- 請勿撞擊或敲打本儀器，否則可能導致故障。
- 儀器維修須由台灣圓點奈米技術股份有限公司授權之單位執行。
- 儀器僅可使用台灣圓點奈米技術股份有限公司所提供之原廠零件。
- 若本設備未依製造商指定方式使用，儀器之防護功能可能無法正常發揮或失效。
- 使用者與 / 或病患若發生與本裝置有關之嚴重事件，應通報製造商及其所屬成員國主管機關。

1.簡介

關於

Maelstrom Switch 8 是專為靈活應用設計之自動化核酸平台，具備直覺式操作介面，並相容多數主流品牌試劑套組。透過專用旋轉套可提升磁珠混合效率。Maelstrom Switch 8 能將傳統常規操作流程轉化為自動化無人化處理，顯著提升分子實驗室之生產力。

運作原理

Maelstrom Switch 8 利用磁棒進行磁珠之收集與轉移，並藉由旋轉套進行檢體與緩衝液之混合，旋轉套具備良好之混合效率，延伸式磁棒則可有效收集磁珠。經過細胞裂解、核酸吸附、洗滌與洗脫步驟後，可獲得純化之核酸。

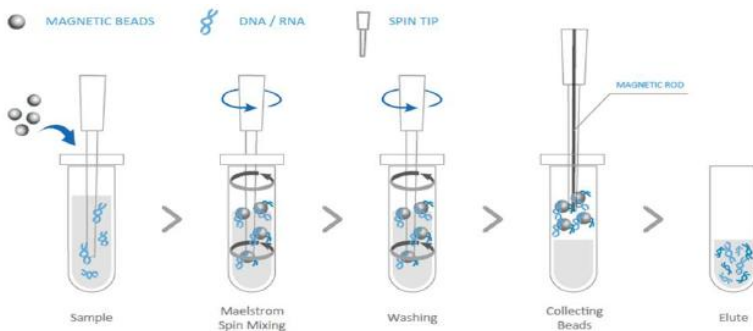

1.簡介

預期用途

Maelstrom Switch 8 建議由受過訓練之人員於自動化環境下於醫學實驗室中操作使用。此儀器適用於於微量反應盤格式中自動轉移與處理磁性顆粒，以自樣本中萃取並純化核酸。純化後之核酸可應用於採用 PCR 為基礎之定性、半定量及定量分析等後續實驗流程。

1.簡介

樣本種類

Maelstrom Switch 8 自動化核酸萃取儀不適用於樣本採集。儀器可搭配各類型或品牌之磁珠式萃取試劑使用，並不限於 TANBead 核酸萃取試劑套組。請參考下方樣本類型及相容試劑組合作為使用參考。

樣本	試劑組合		
Blood	61E series	611 series	621 series
cfDNA	622 series 61C series		
Virus	615 series 685 series 61G series	635 series 61H series 61G-SE series	665 series
Bactria	6BG series		6MB series
Tissue	6T2 series	6K2 series	
FFPE	61P series	62P series	
Stool Plant Fungi/ yeast Environment sample Food and feed Forensic	6SC series 613 series 61F series 6EM series 6GM series 6TF series	613 series	6K3 series
Plasmid	6PE series		

1.簡介

環境要求

為避免縮短儀器之使用壽命，請於符合以下條件之環境中使用 Maelstrom Switch 8：

- 請放置於空氣流通之位置。
- 請放置於可承載至少 20 公斤之桌面或平台上。
- 請勿於溫濕度變化劇烈之環境中使用本儀器。
- 操作環境條件：
溫度：10–40°C
相對溼度：40–80%
- 儲存與運輸環境條件：
溫度：5–50°C
相對溼度：20–85%
- 使用高度限制：
海拔低於 2000 公尺

1. 簡介

安全說明及指南

- 本設備可能涉及生物危害性物質之操作，請配戴適當的個人防護裝備（如手套、防護眼鏡、實驗衣等）以處理與廢棄相關樣本。
- 在正常運作情況下，Maelstrom Switch 8 的音壓值不超過 80 分貝，不會造成危害。若發現音壓異常偏高，請聯繫技術支援以獲得協助。
- 由於本設備涉及化學與生物危害物質使用，具有潛在風險。使用者應遵守其所屬機構之相關規範，妥善處理與棄置所有具感染性之樣本與廢棄物。每次使用後應清潔儀器。
- 若樣本或試劑有灑落情形，請立即清潔設備，以避免損壞或交叉污染。
- 本設備須搭配相容之旋轉套（Spin Tips）使用，若使用不相容之耗材，可能導致萃取效能不佳。
- 在操作本設備前，請完整閱讀本使用手冊。
- 未依本手冊指引閱讀、理解並遵循操作，可能導致設備損壞、實驗人員受傷或實驗效能不佳。
- 本儀器內含多顆電池，符合歐盟電池法規 (EU) 2023/1542 的規定。這些電池符合化學物質限制標準，已依據該法規加貼 CE 標誌，並須遵守歐盟的回收與再利用義務。

1.簡介

安全說明及指南

Maelstrom Switch 8 設備已通過測試，符合以下標準：

- IEC 61010-1:2010+A1:2016 (第 3.1 版) 與 EN 61010-1:2010+A1:2019 所規範之「測量、控制與實驗室用電氣設備之安全要求 - 第 1 部分：一般要求」。
- IEC 61010-2-101:2018 搭配 IEC 61010-1:2010+A1:2016 及 EN 61010-2-101:2017 搭配 EN 61010-1:2010+A1:2019 所規範之「測量、控制與實驗室用電氣設備之安全要求 - 第 2-101 部分：體外診斷 (IVD) 醫療設備之特殊要求」。

EMC 要求

Maelstrom Switch 8 設備已通過測試，符合以下標準：

- IEC 61326-1:2020 / EN IEC 61326-1:2021
- IEC 61326-2-6:2020 / EN IEC 61326-2-6:2021

上述標準為「測量、控制與實驗室用電氣設備 - 電磁相容性 (EMC) 要求 - 第 2-6 部分：體外診斷 (IVD) 醫療設備之特殊要求」。

2.儀器概述

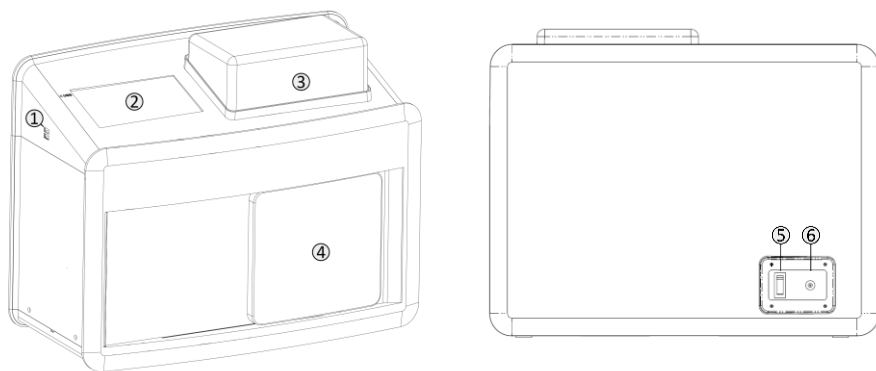

- ①USB 接口
- ②觸控螢幕
- ③齒輪箱蓋
- ④前門
- ⑤電源開關
- ⑥電源插座

2.儀器概述

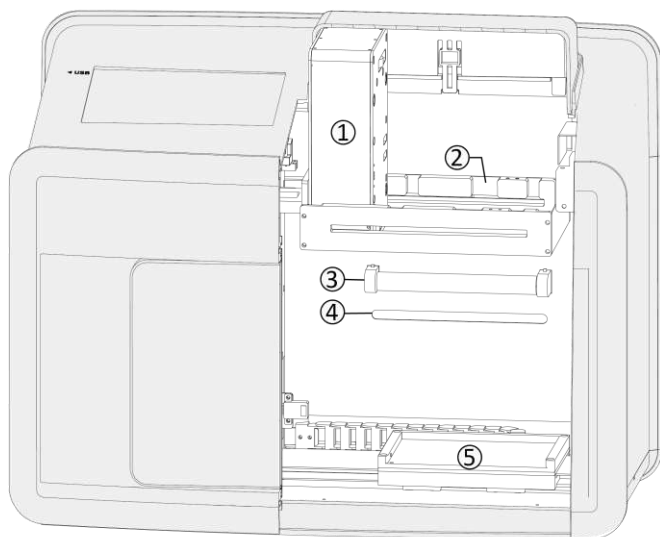

- ①傳動齒輪箱
- ②導軌
- ③紫外線燈
- ④LED 燈
- ⑤載物台，請勿手動移動載物台。

2.儀器概述

配件清單

儀器所檢附之配件，會依各國家而有所不同。



電源線

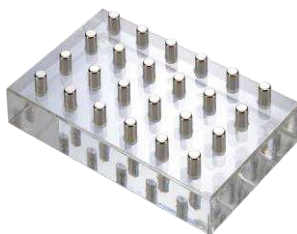

磁座







電源變壓器

2.儀器概述

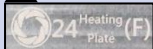
相容齒輪箱組

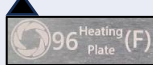
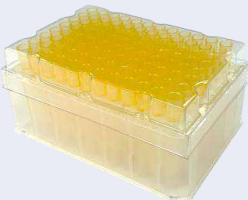
(A) 大磁棒齒輪箱組 (適用於領導品牌試劑)

齒輪箱	加熱盤	耗材
<p>CH 4 Gearbox Ø7.5(A)</p> 	<p>24 Heating Plate F</p>   加熱底座上標示「F」者，適用於 Ø7.5 磁棒 (A 類型)	<p>24 Spin Tips (Ø7.5) Assembled Box</p> 
<p>CH 8 Gearbox Ø3.5(A)</p> 	<p>96 Heating Plate F</p>   加熱底座上標示「F」者，適用於 Ø3.5 磁棒 (A 類型)	<p>96 Spin Tips (Ø3.5) Assembled Box</p> 
<p>CH16 Gearbox Ø3.5(A)</p> 		

2.儀器概述

(B) 小磁棒齒輪箱組 (適用於 TANBead 預填充試劑)

齒輪箱	加熱盤
<p>CH 4 Gearbox Ø4.2(B)</p> 	<p>24 Heating Plate</p> 
<p>CH 8 Gearbox Ø2.2(B)</p> 	<p>96 Heating Plate</p> 
<p>CH16 Gearbox Ø2.2(B)</p> 	

2.儀器概述

Maelstrom Switch 8 需搭配專用設計以達最佳處理效能。請依所使用之磁棒類型，搭配相應之旋轉套組盒與深孔盤使用。若使用非指定之耗材，可能導致儀器損壞並影響保固效力。如需使用建議以外之耗材，請聯繫我們 (service@tanbead.com) 以獲得進一步協助。

(A) 大磁棒齒輪箱組 (適用於領導品牌試劑)



24 Spin Tips (Ø7.5)
Assembled Box



96 Spin Tips (Ø3.5)
Assembled Box



24 Deep Well Plate, v-bottom F
Dimensions:
Length (L): 127.40 ±0.5 mm
Width (W): 85.48 ±0.5 mm
Height (H): 44.20 ±0.5 mm



96 Deep Well Plate, v-bottom F
Dimensions:
Length (L): 127.76 ±0.5 mm
Width (W): 85.48 ±0.5 mm
Height (H): 44.60 ±0.5 mm

2.儀器概述

(B) 小磁棒齒輪箱組 (適用於 TANBead 預填充試劑)



Spin Tips LV



96 Deep Well Plate



24 Spin Tip LV Holder



16 Base B



24 Deep Well Plate



6 Tube B



24 Deep Well Plate LV Base



Spin Tips Assembled Box

3.儀器規格

繁體中文

Maelstrom Switch 8	規格					
重量	N.W. 16.2 kg ; G.W. 23.0 kg					
材積	Instrument: 524(W) x 265(D) x 412(H) mm Package: 638(W) x 426(D) x 568(H) mm					
電器規格	I/P: 100~240V AC, 2.8A Max, 50/60Hz O/P: DC 24V, 8.3 A					
轉速	500~3,000rpm					
顯示螢幕	7" touch screen					
UV 燈	UV-C					
磁棒類型	(A) 大磁棒			(B) 小磁棒		
通量	CH 4	CH 8	CH16	CH 4	CH 8	CH16
齒輪箱						
每次處理通量	1~4	1~8	1~16	1~4	1~8	1~16
Rod Size	Ø7.5(A)	Ø3.5(A)		Ø4.2(B)	Ø2.2(B)	
磁力 (Gauss)	5,400	4,700		4,700	3,900	
處理體積 (µL)	150~5,000 Max. 1500 rpm	50~1,200		100~9,000	50~1,600	
應用試劑	相容於各主流磁珠型試劑品牌使用			TANBead：預填充孔盤、預填充單管、瓶裝格式		
儲存程序	可自行設定程序，或由 TANBead 技術團隊協助建立			TANBead 內建程序		

4. 安裝與啟動

請注意，本產品重量約 20 公斤，建議由兩人以上共同搬運以確保操作安全。

步驟 1：

安裝系統自包裝箱中取出儀器，建議由兩人以上共同操作。

步驟 2：移除儀器外部與內部之保護緩衝材。

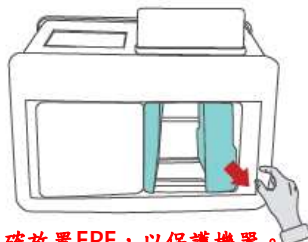

運輸過程中請務必使用並正確放置EPE，以保護機器。

步驟 3：將儀器放置於平坦且可承重超過 20 公斤之桌面或平台上。

步驟 4：安裝齒輪箱請依所使用之耗材類型，參考下列程序安裝齒輪箱模組。

(A):將齒輪箱放置於導軌上



安裝齒輪箱前，請勿開啟電源。操作齒輪箱時，請確認磁棒未接觸或撞擊任何部件，以避免損壞。

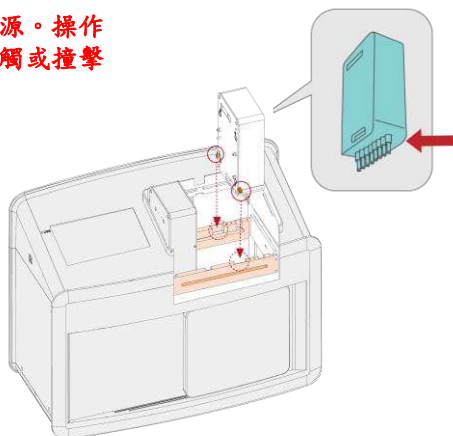

4. 安裝與啟動

(B) :將齒輪箱推至左側

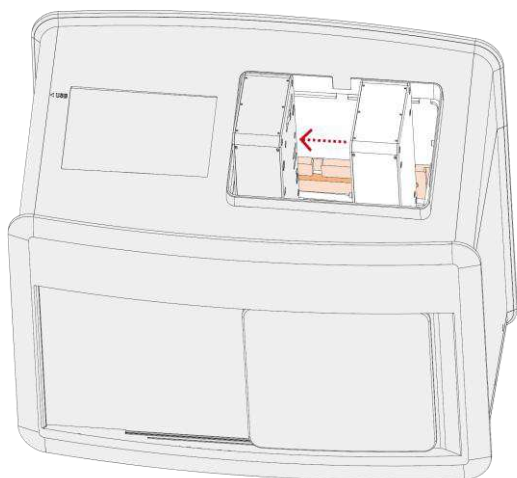

(C) :確認齒輪箱緊密貼合

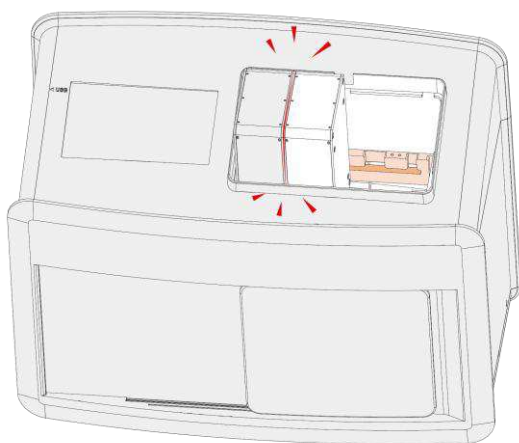

4.安裝與啟動

(D) :依需求安裝 96 孔或 24 孔加熱底座



安裝加熱底座時，請保持水平放置。

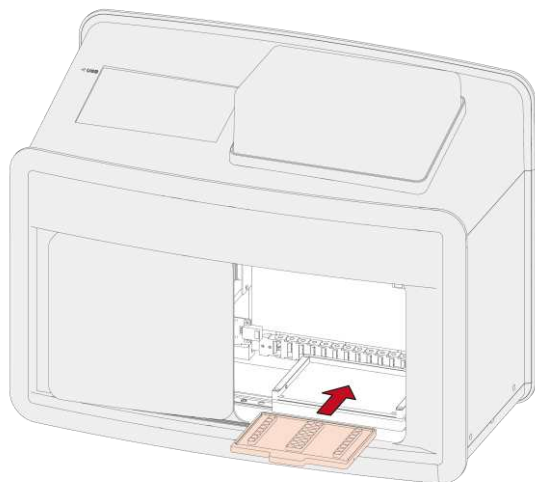

加熱底座於運作或更換期間表面可能處於高溫狀態，請小心操作以避免燙傷風險。

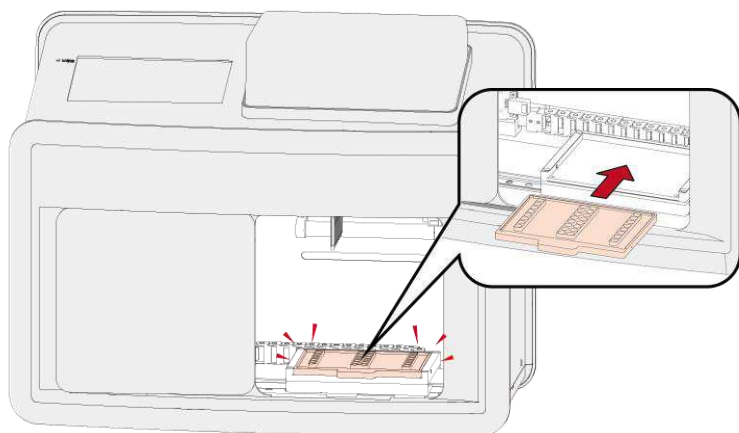

注意:

標示有「F」字樣之加熱底座僅支援 A 類型磁棒 (Ø7.5/Ø3.5) ;
未標示「F」者僅支援 B 類型磁棒 (Ø4.2/Ø2.2) 。

4. 安裝與啟動

步驟 5：接上電源線請連接電源線與電源變壓器。

請注意：本儀器僅支援 AC 100–240V 電源。使用錯誤電壓可能導致儀器故障或損壞。

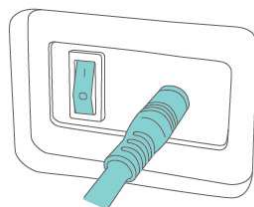

步驟 6：開機打開電源後，儀器將自動進行初始化作業。

警告：本產品內含強力永久磁鐵。配戴心律調節器或金屬義體之人員請勿使用本產品。若此類裝置接近強磁場，可能受到干擾或損壞。

步驟 7：選擇磁棒類型請依齒輪箱上標籤選擇正確型號，並點選「Yes」進行確認與下一步操作。

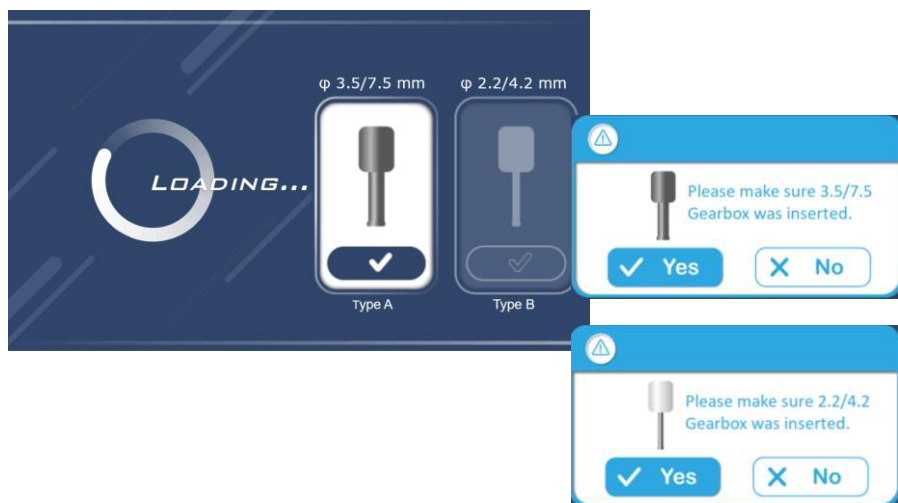

4.安裝與啟動

步驟 8：輸入使用者密碼請參考後續章節進行軟體操作。

系統啟動後，請輸入使用者密碼登入：

「222」為管理者模式 (Supervisor Mode)

「333」為操作人員模式 (Operator Mode)

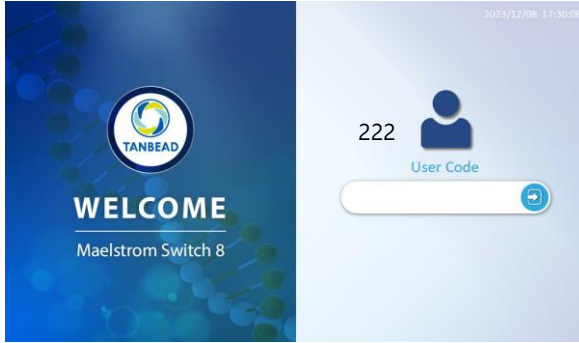

系統將依輸入的使用者密碼顯示不同之主畫面介面。



User code: 222



User code: 333

4. 安裝與啟動

步驟 9：編輯程序（適用於主流品牌試劑）

請參考第 5 章「編輯」功能，設定對應反應試劑之操作程序。

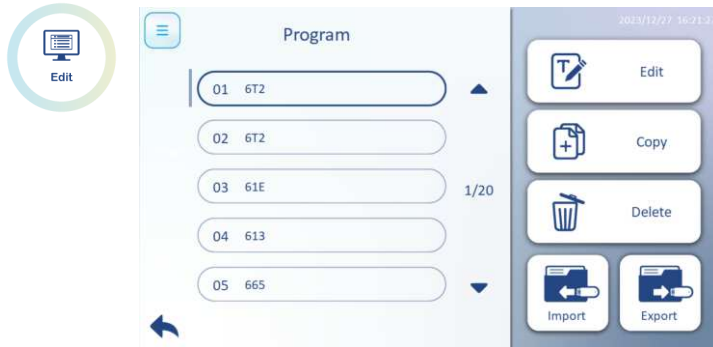

步驟 10：執执行程序點選「Run」並選擇對應程序以開始萃取，然後點擊「▶」圖示以繼續執行流程。



4.安裝與啟動

- 請選擇「L」以操作孔盤左側，或選擇「R」以操作右側，然後點選「」以繼續。請依使用容器類型選擇「Auto-plate」或「Auto-Tube」，並點選「」以開始執行程序。

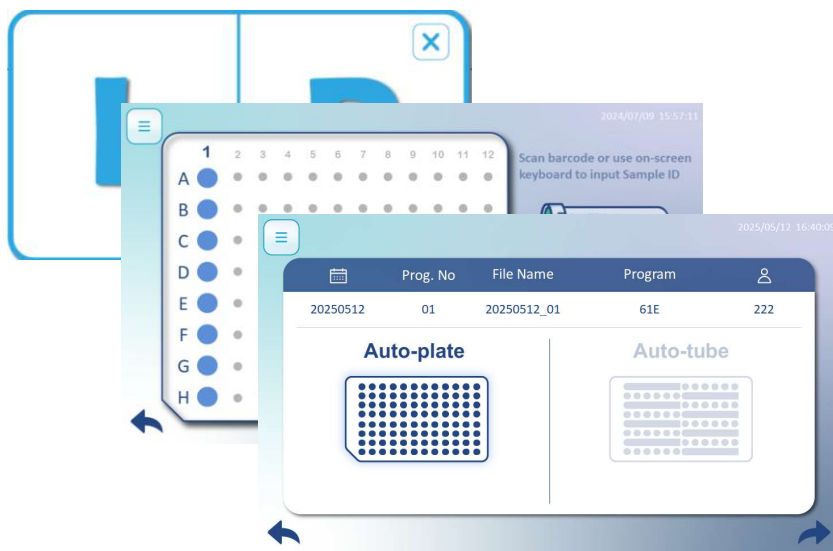

4. 安裝與啟動

- 放置旋轉套組盒後，請點選「插套」以拾取選定通道之旋轉套。

注意：此操作僅適用於 8 通道齒輪箱。為確保操作正確，請於進行樣本萃取時，使用對應孔盤側之左側或右側旋轉套組盒。

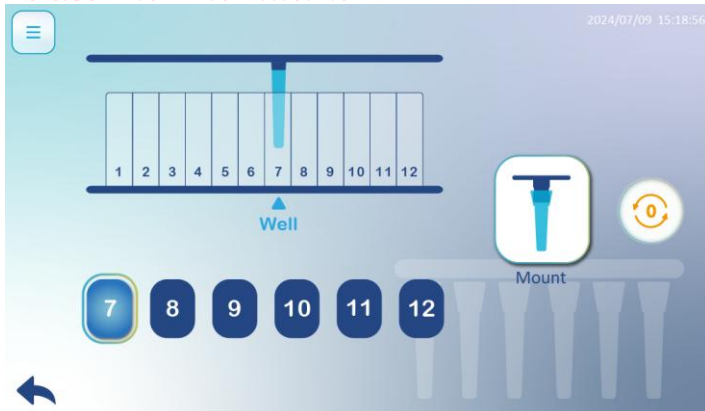

- 旋轉套拾取完成後，系統將顯示警示訊息。請確認已將準備好的反應盤放入儀器內，然後點選「Yes」以繼續操作。

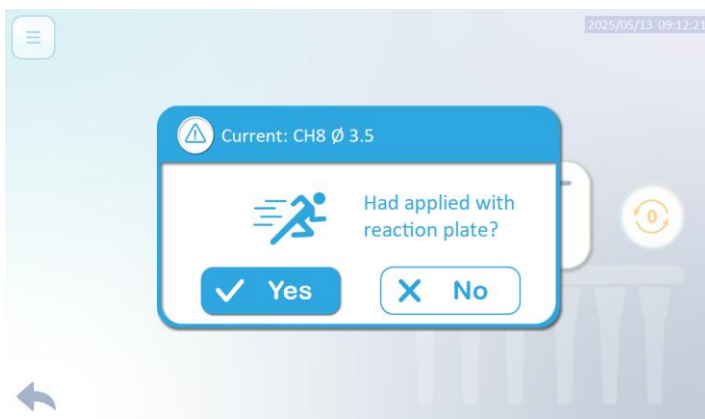

4.安裝與啟動

- 當溫度加熱至設定值後，程序將自動開始執行。

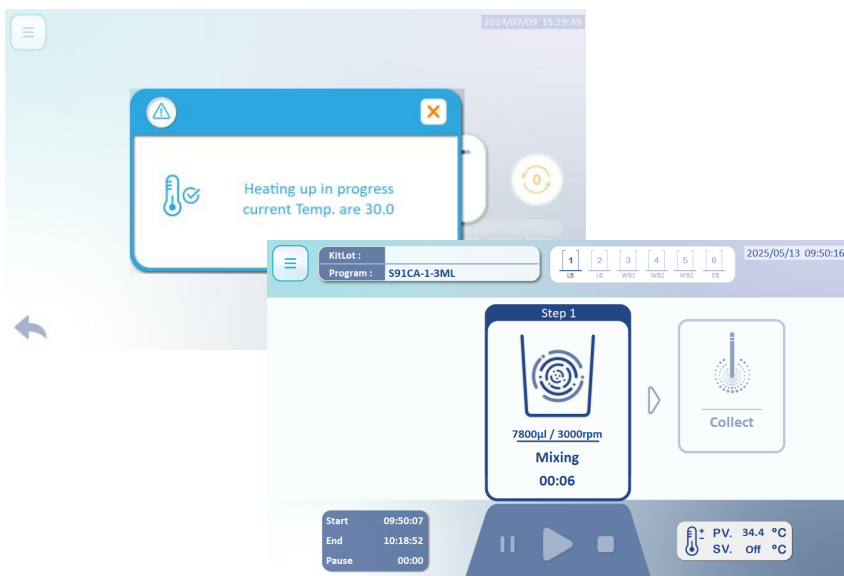

- 程序完成後，請點選「Report」以檢視操作流程細節。關閉報告後，系統將跳出提示視窗。

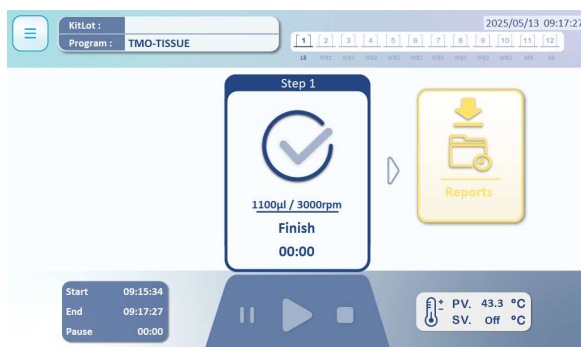

4.安裝與啟動

- 請選擇欲退套之通道後執行「退套」操作，完成後可返回主畫面。

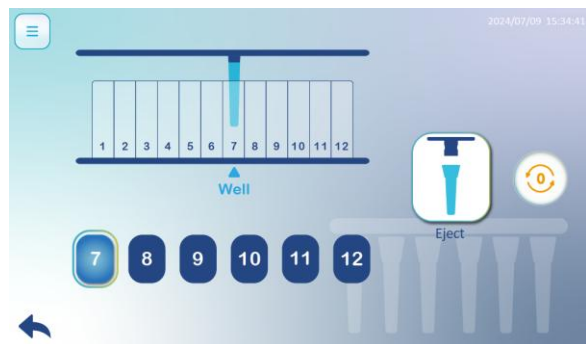

5. 軟體應用

初始化



開啟儀器電源後，請稍待數秒以完成系統初始化。請依齒輪箱上方之標籤選擇正確型號，點選「Yes」以確認並繼續操作。

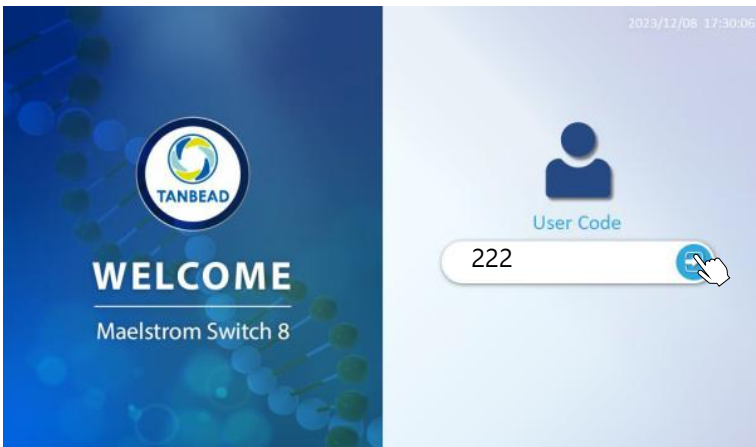

請輸入「222」作為管理者模式 (Supervisor Mode)，或輸入「333」作為**操作人員模式 (Operator Mode) **以登入系統。若遺忘密碼，請聯繫當地經銷商或台灣圓點奈米技術股份有限公司尋求協助。

5. 軟體應用

- 進入主畫面後，系統將自動辨識齒輪箱類型，並顯示相對應之操作介面。
- 各圖示功能將依偵測到之齒輪箱類型有所不同。

CH 4 Gearbox



CH 8 Gearbox



CH16 Gearbox



5.軟體應用

一般功能:

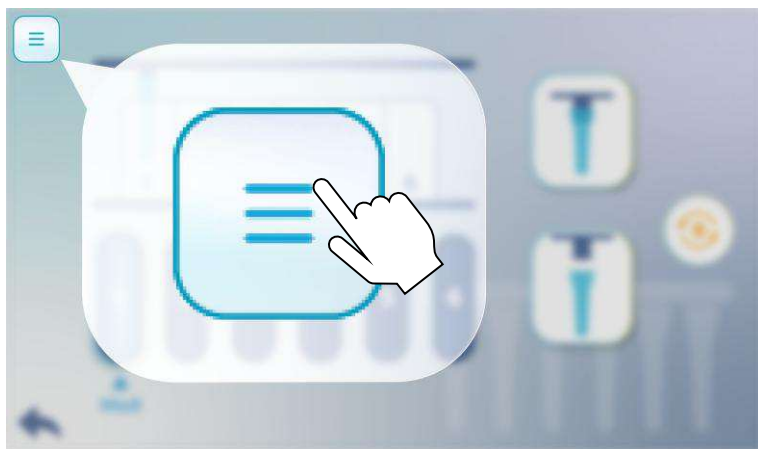

點擊工具欄使用以下功能



- ① 主頁面
- ② LED燈開關
- ③ 版本訊息
- ④ 軟體更新

5.軟體應用

Maelstrom Switch 8 的「主畫面」可操作以下功能。顯示介面將依所使用之齒輪箱類型而有所不同。

主畫面 (以 CH 8 齒輪箱為例)



- ① 更換使用者
- ② 當前溫度
- ③ 當前齒輪箱類型

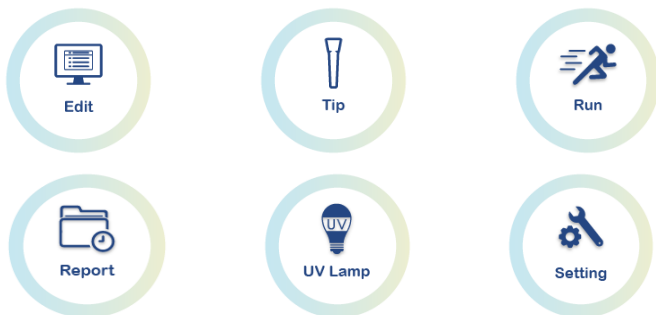

- Edit：編輯程序
- Tip：退套
- Run：進入「執执行程序」
- Report：管理歷史資料
- UV Lamp：開啟 / 關閉紫外燈
- Setting：調整轉移平台參數。

5.軟體應用



Edit：編輯程序

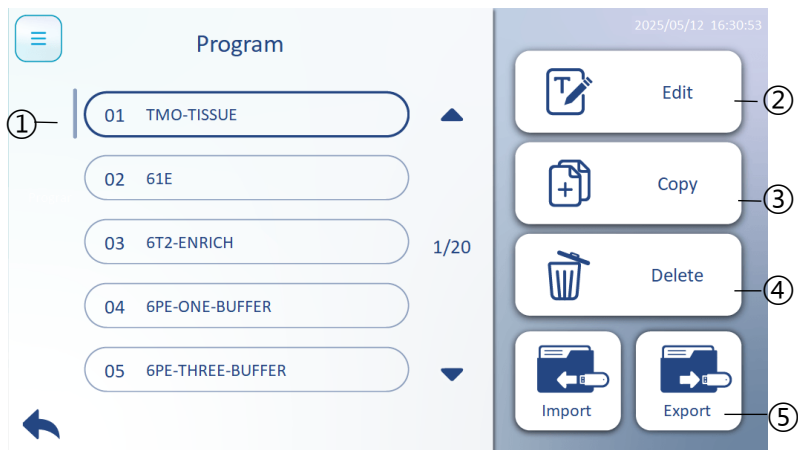

點選以進入「編輯」功能，可修改現有程序，或依試劑套組需求建立自訂程序。使用不同齒輪箱時，建議為每種配置分別建立對應程序。

- ① **Program**：顯示所有程序列表
- ② **Edit**：輸入選定之程序編號以修改操作流程
- ③ **Copy**：將選定程序複製至其他程序編號
- ④ **Delete**：點選以刪除選定之程序
- ⑤ **Import/Export**：使用 USB 裝置匯入或匯出程序至系統中

5. 軟體應用



編輯現有程序。



Edit

編輯選定之程序。

以 CH 8 齒輪箱作為操作說明範例：

2025/05/13 10:02:10

① Number 02

② Program 61E

③ Heating (°C) 45

Well	Name	Volume(μl)	Action
1 • 7	LB	1100	Rev. U/D
2 • 8	WB1	800	For.
3 • 9	WB2	800	For.
4 • 10	WB2	800	For.
5 • 11	MB	800	For.
6 • 12	EB	100	For.

④

⑤

2025/05/12 16:33:05

Number 01

Program TMO-TISSUE

Heating (°C) 45

Well	Name	Volume(μl)	Action
7	WB2	1100	For.
8	WB2	800	Rev.
9	WB2	800	For. U/D
10	WB2	800	Rev. U/D
11	MB	800	For. U/D
12	EB	100	Rev. U/D

- ① Number：用於儲存之程序編號
- ② Program：程序名稱
- ③ Heating：啟用預熱功能並設定加熱溫度
- ④ Protocols：預覽程序內容
- ⑤ 「Previous」返回上一步，「Next」進入詳細程序設定

5.軟體應用



編輯現有程序。



編輯選定之程序。

程序預覽

	①	②	③	
Well	Name	Volume(μ l)	Action	
1 • 7	LB	900	Foc	▼
2 • 8	WB1	800	Foc	▼
3 • 9	MB	800	Foc	▼
4 • 10	WB2	800	Foc	▼
5 • 11	WB2	800	Foc	▼
6 • 12	EB	130	Foc	▼

預覽程序內容並進入相關設定：

- ① **Name**：點選以選擇各步驟所使用之緩衝液名稱
- ② **Volume**：點選以輸入各孔位之樣本體積
- ③ **Action**：點選以選擇旋轉模式，包括「反轉」、「正轉」、「反轉並上下混合」與「正轉並上下混合」

①

Well	Name	Volume(μ l)	Action
1 • 7	LB	900	Foc
2 • 8	LB	800	Foc
3 • 9	WB2	800	Foc
4 • 10	MB	800	Foc
5 • 11	WB3	800	Foc
6 • 12	EB	800	Foc
6 • 12	EB	130	Foc

②

50 ~ 1600			
7	8	9	←
4	5	6	-
1	2	3	
0	.	OK	

③

Well	Name	Volume(μ l)	Action
1 • 7	LB	900	Foc
2 • 8	WB1	800	Foc
3 • 9	MB	800	Foc
4 • 10	WB2	800	Rev. U/D
5 • 11	WB2	800	Rev. U/D
6 • 12	EB	130	Foc

5.軟體應用



編輯選定程序。



Edit

Edit : 編輯程序

Detail protocol setting:



預覽程序內容後，點選顯示數值以進入對應參數設定。可使用「Delete」刪除步驟、「Copy」複製步驟，以及「Save」儲存程序設定。

注意：編輯程序時，請避免將磁珠與已退套之旋轉套放置於同一孔位。

各設定項目說明如下：

- ① Step：齒輪箱動作之執行順序
- ② Well：每步驟對應之處理孔位（依齒輪箱類型可能不同）
- ③ Temp.：該步驟之加熱開關與溫度設定
- ④ Mixing Time：混合時間長度設定
- ⑤ Spin Speed：攪拌旋轉速度設定
- ⑥ Collect Time：磁棒收集磁珠所需時間設定
- ⑦ Vapor Time：磁珠風乾所需時間設定
- ⑧ Pause：啟用或關閉暫停功能，用於暫時中止程序

5.軟體應用



編輯現有程序。



Copy：將選定之程序編號複製至指定位置。

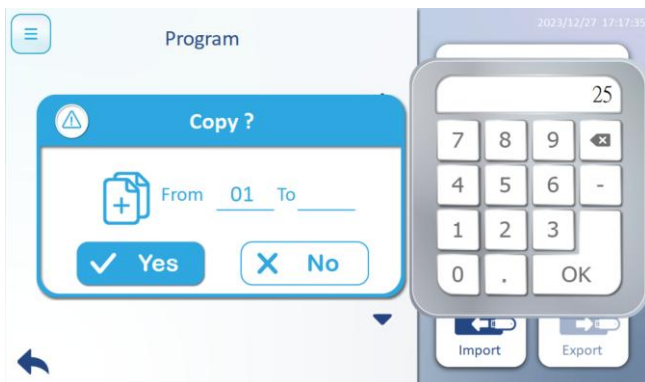

Delete：刪除選定之程序編號。



Import/Export：可透過 USB 裝置匯入或匯出程序，格式為 CSV。

下方顯示檔案格式範例。

	A	B	C	D	E	F	G	H	
1	Temp1	Temp2							
2	40	40							
3									
4	Well	Name	Volume	Action	Mixing	Collect			
5		1 LB	900	Rev. U/D	Low	Low			
6		2 WB1	800	For.	Low	Low			
7		3 WE2	800	For.	Low	Low			
8		4 WE2	800	For.	Low	Low			
9		5 MB	800	For.	Low	Low			
10		6 EB	150	For.	Low	Low			
11									
12									
13	Step	Well	Temp	Mix_time	Mix_spee	Collect_ti	Vapor_tin	Pause	
14		1	5		0	3000	0.1	0 Off	
15		2	1	65		6	3000	0.5	0 Off
16		3	2		0.5	3000	0.1	0 Off	
17		4	3		1	3000	0.2	0 Off	
18		5	4		0.5	3000	0.2	7 Off	
19		6	6	45		3	3000	0.5	0 Off
20		7	3		0.1	3000		0	0 Off

請勿更動 CSV 檔案之內部格式。

修改資料位置或排列方式可能導致程序執行錯誤。

5.軟體應用



退套

畫面配置將依所使用之齒輪箱類型有所不同，惟功能圖示將保持一致。執行旋轉套退套操作時，建議使用空的反應盤以進行操作。



請使用與所安裝之齒輪箱相容的正確耗材。

CH 8 Gearbox

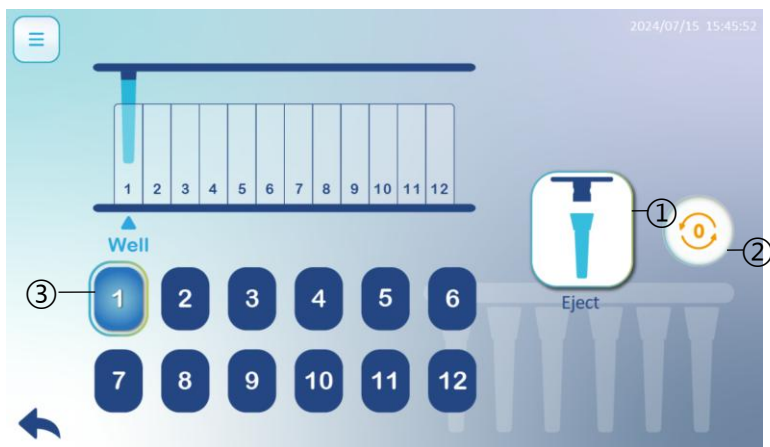

注意：在開始執行程序前，請確認齒輪箱或儀器腔體內無殘留旋轉套。

Eject Tip：點選圖示以退套

Origin：點選圖示以執行儀器原點復歸

Well：點選圖示（1~12）於不同孔位執行退套操作

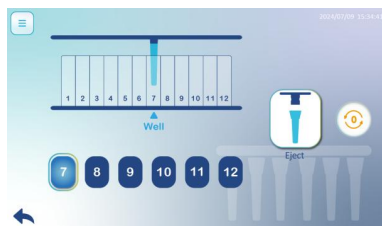
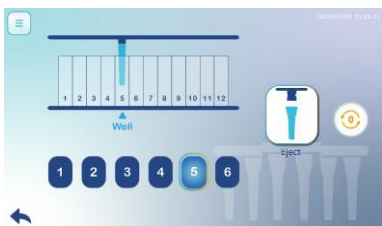

5.軟體應用



退套



請使用與已安裝齒輪箱相容之正確耗材。

CH 4 Gearbox

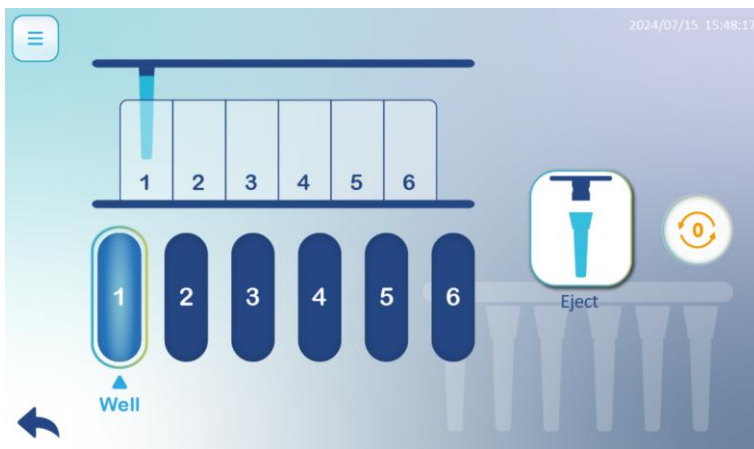

CH16 Gearbox

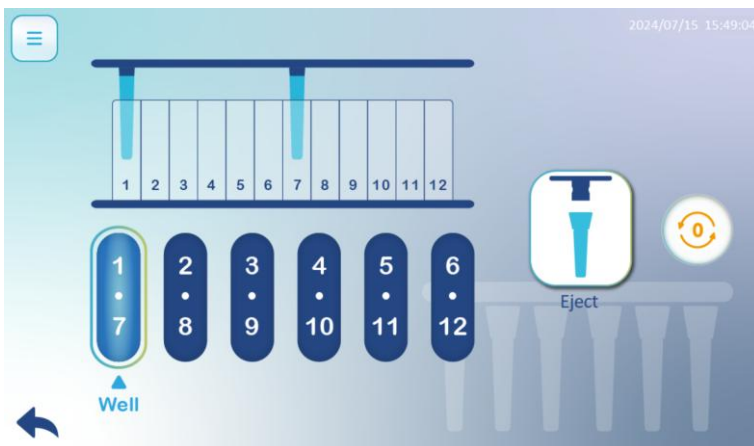

5.軟體應用



執程序序

請雙擊選定之程序以開始執行。



Switch 8 最多可儲存 100 組程序，具備高度彈性。

請選擇對應您試劑套組之操作程序。

如有需要，可使用搜尋欄輸入關鍵字以快速尋找所需程序。

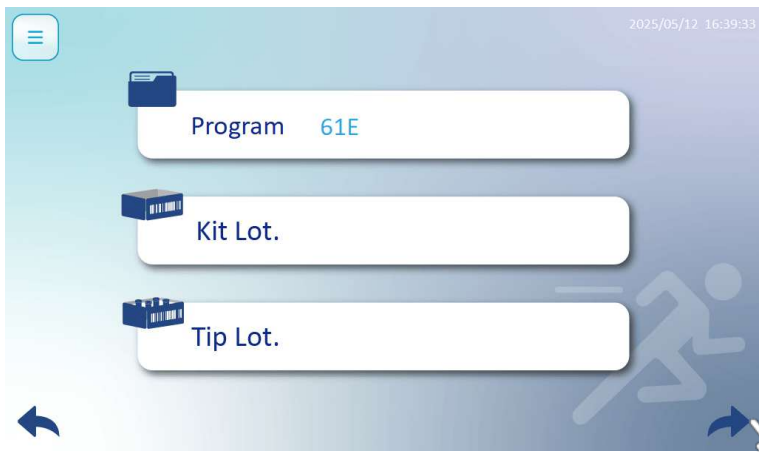

請輸入試劑批號與旋轉套批號，以利後續實驗追蹤。點選「」以進入下一頁。

5.軟體應用



執行程序

請上下滑動以檢視所選程序設定內容，確認後點選「➡」以繼續進行。

Number: 02
Program: 61E

Step	Well	Temp. (°C)	Mixing Time (min)	Spin Speed (rpm)	Collect Time (min)	Vapor Time (min)	Pause On/Off
1	5 · 11		0.1	3000	0.1	0	Off
2	1 · 7	50	0.1	500	0.1	0	Off
3	2 · 8		0.1	3000	0.1	0	Off
4	3 · 9		0.1	500	0.1	0	Off
5	4 · 10		0.1	3000	0.1	10	Off

2025/05/12 16:39:43

當使用 CH8 齒輪箱並執行 6 步驟程序時，使用者可選擇操作深孔盤的「左側」或「右側」區域。但此選項不適用於其他齒輪箱類型或 12 步驟程序。

Number: 04
Program: 6PE-ONE-BUFFER

Step	Well	Temp.	Mixing	Spin	Collect	Vapor	Pause On/Off
1	5 · 11						Off
2	1 · 7						Off
3	2 · 8						Off
4	3 · 9						Off
5	4 · 10		0.1	3000	0.1	10	Off

2025/05/13 09:09:05

Selection dialog: L (Left) or R (Right)

請選擇「左側 (Left)」或「右側 (Right)」區域以執行程序。
選擇「左側」表示處理第 1 至第 6 通道；
選擇「右側」則表示處理第 7 至第 12 通道。

5.軟體應用



執程序序

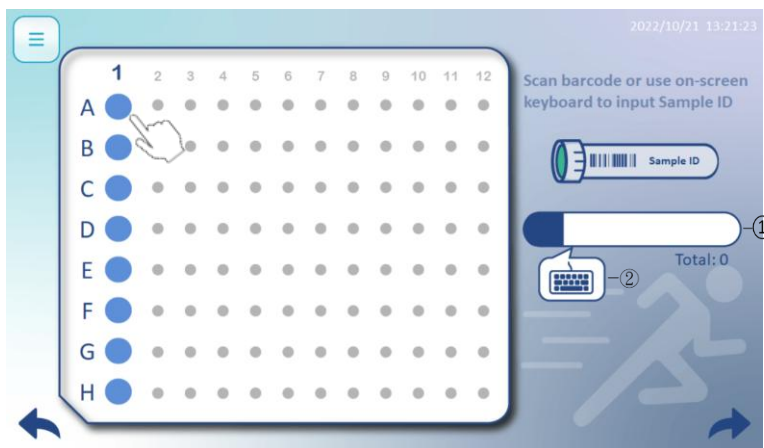

請點選圓點 (A1~H1) ，以輸入樣本編號，可透過 ① 條碼掃描 或 ② 手動輸入方式完成。

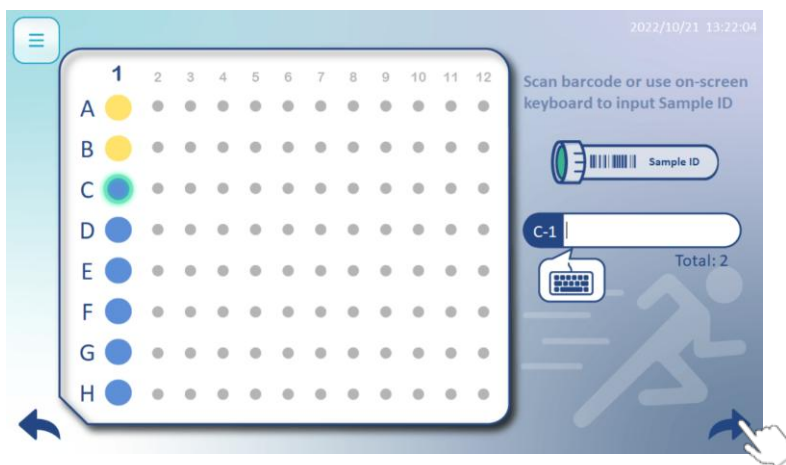

當樣本編號輸入成功後，圓點指示燈將變為黃色，系統將自動移至下一個樣本位置 (例如：A1 → B1，B1 → C1 依此類推)。點選「」以進入下一頁。

注意：

輸入資料時，請小心避免誤觸相鄰按鈕或區域，以免造成輸入錯誤。



5.軟體應用

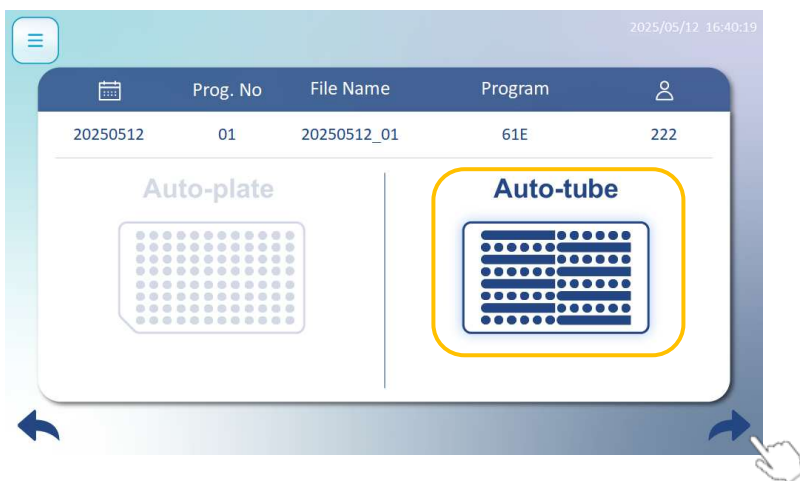
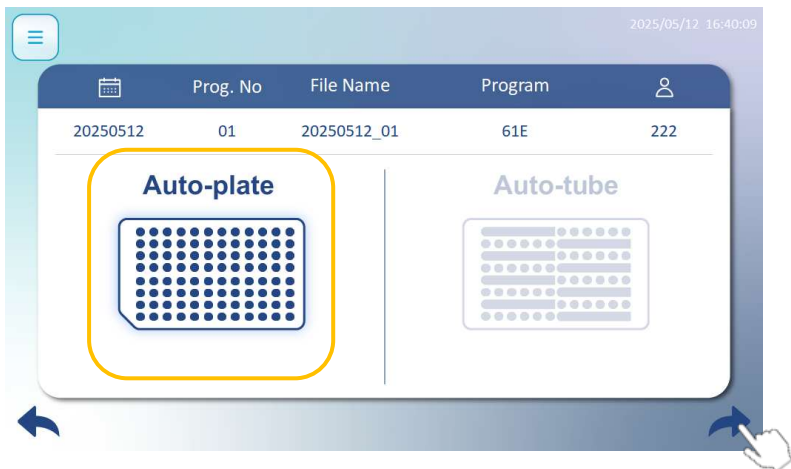

執行程序

請依所使用之孔盤格式選擇「Auto-Plate」或「Auto-Tube」以繼續操作。



請確認以上資訊（如日期、程序、檔案名稱）是否正確。點選「」圖示以執行程序，或點選「」圖示返回上一步。

5. 軟體應用



執行程序

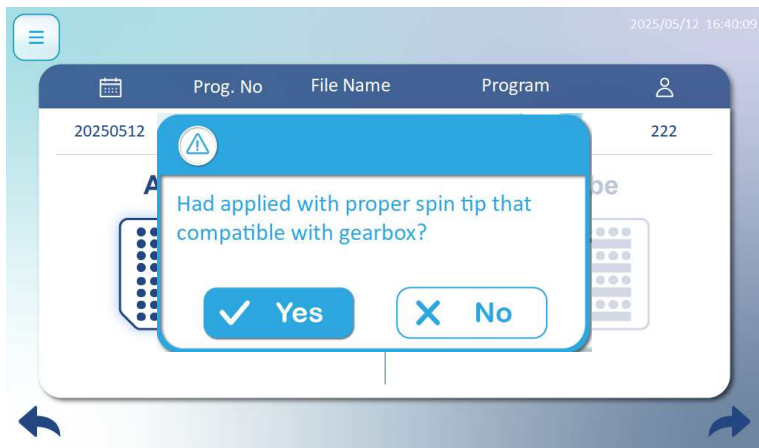

點選「」圖示後，系統將顯示警示視窗。請確認已正確放置旋轉套組盒於系統內，然後點選「Yes」以繼續，或點選「No」返回上一頁。

插套

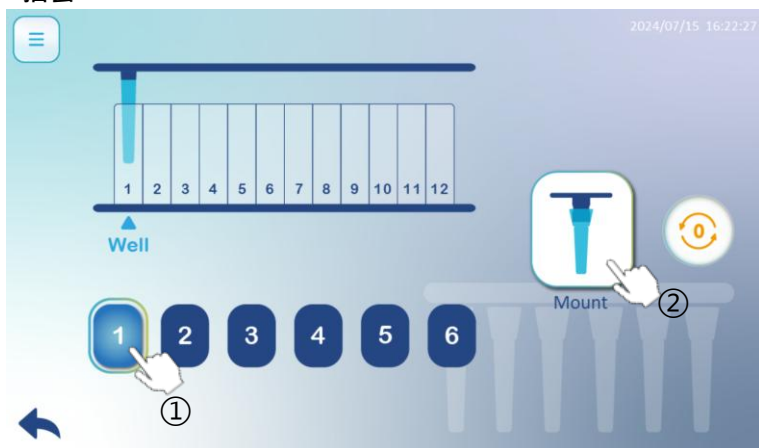

請將旋轉套組盒放置於 Switch 8 內部之加熱底座上。

- ① 選擇欲使用之通道
- ② 點選「Mount」以拾取旋轉套

5.軟體應用



執行程序

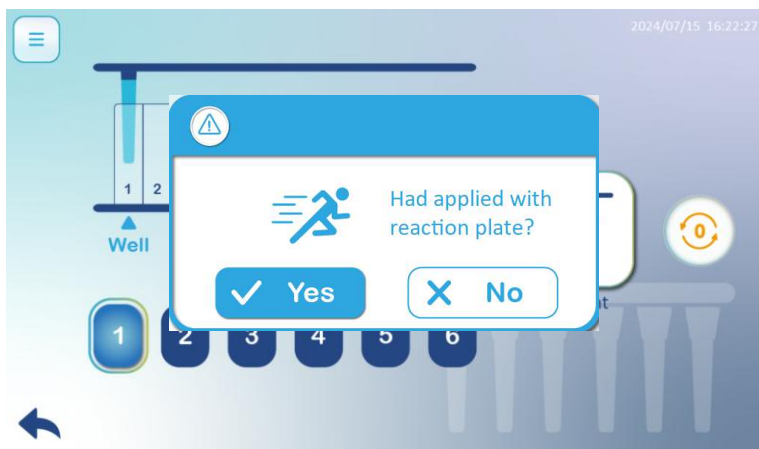

旋轉套拾取完成後，請務必將旋轉套組盒更換為已準備好的反應盤。
若已完成放置，請點選「Yes」以繼續；若尚未放置，請點選「No」。

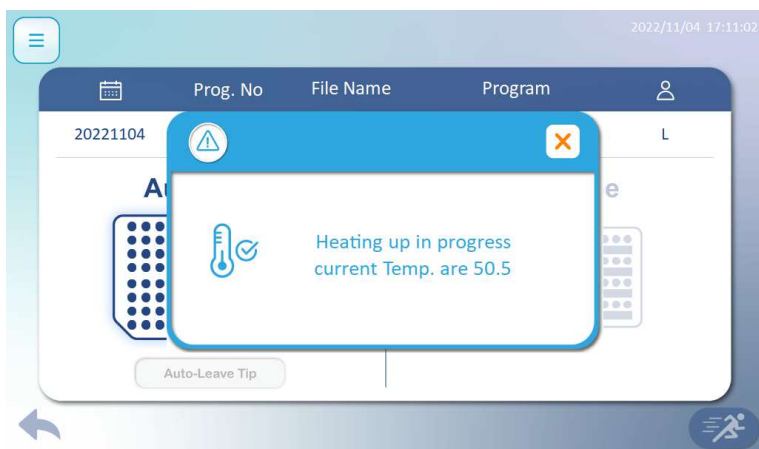

當溫度達到設定值後，程序將自動開始執行。

5.軟體應用



執执行程序

運行狀態：



建議您熟悉以下符號，有助於了解目前程序執行狀態：

Current Step：顯示目前執行之步驟

Start Time / Estimated End Time / Pause Time：顯示程序開始時間、預計完成時間與暫停時間

PV / SV：PV 為實際溫度，SV 為當前步驟之設定溫度



暫停: 暫時停止萃取流程



繼續: 繼續暫時停止的萃取流程



停止: 強迫停止萃取流程

5.軟體應用



執行程序



攪拌: 此步驟是混合磁珠和試劑檢體



磁吸: 此步驟是收集孔盤內磁珠。點擊暫停或是停止鍵，Maelstrom Switch 8 將先完成整個磁吸動作才會暫停或停止。



風乾: 此步驟是揮發殘留在磁珠上的醇類。



程序完成: 此步驟是運行結束，蜂鳴器會自動響起數秒後停止。



暫停: 暫時終止萃取流程

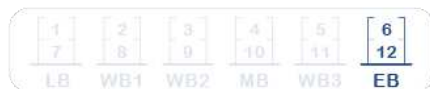

孔位1~12 會根據使用試劑不同而更改名稱。

5.軟體應用



執程序序

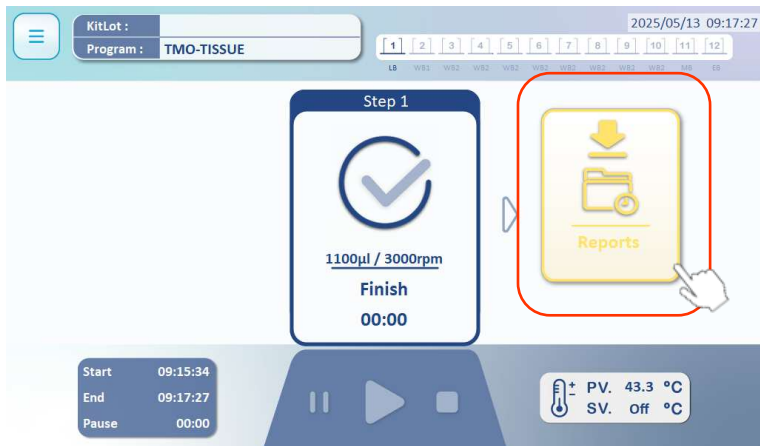

程序完成後，請點選「Report」以檢視執行結果。

為完成整體操作流程，請執行旋轉套退套動作。
請選擇與含有磁珠不同的通道進行退套操作。

注意：請勿將磁珠與已退套之旋轉套置於同一通道內。



5.軟體應用



Reports : 管理歷史資料

請勾選資料項目，以執行刪除或匯出至 USB 裝置。

2022/10/12 16:19:12

	📅	File Name	Kit Lot.	👤	Error	
<input checked="" type="checkbox"/>	20220714	20220714_01		L	00000000	▲
<input checked="" type="checkbox"/>	20220706	20220706_01		L	00000000	
<input type="checkbox"/>	20220706	20220706_02		L	00000000	1/25
<input type="checkbox"/>	20220705	20220705_01		L	00000000	▼

Delete

Page
1/2
100 records per page switch



Export to USB



5. 軟體應用

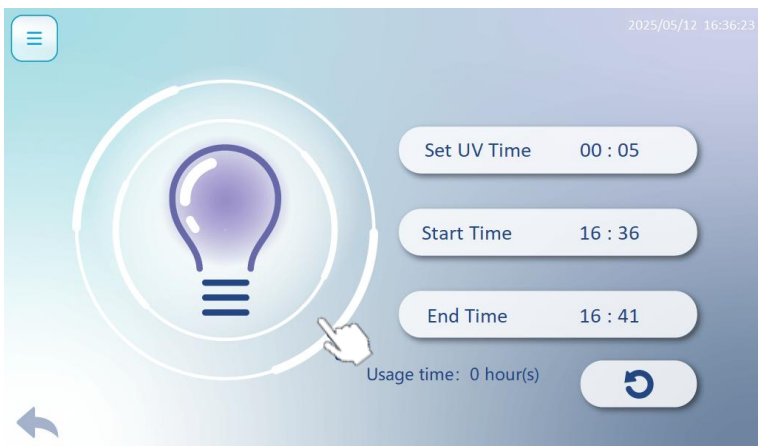

UV Lamp : 開啟 / 關閉紫外燈



請設定紫外燈照射時間，然後點選燈泡圖示以開始運行。



請在開啟紫外燈前先關閉前門。
建議每次照射時間至少為 5 分鐘。

5.軟體應用



Setting :

可透過設定功能調整基本參數，包括使用者管理、語言及時間。

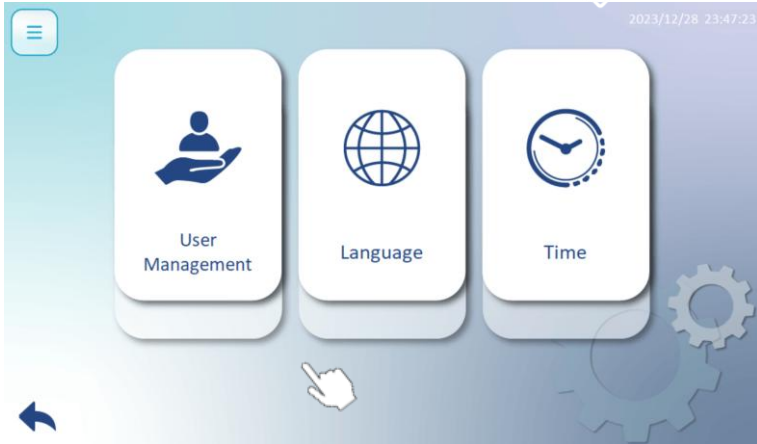

- ① User Management : 可設定操作人員之權限等級
- ② Language : 更改操作介面語言
- ③ Time : 調整儀器系統時間設定

5. 軟體應用

12 步驟程序

當使用 CH8 齒輪箱時，可啟用特殊模式「12 步驟程序」，使用者可自訂反應盤上 12 個通道之處理流程。於「編輯」區段（參見第 34 頁），程序列表中將顯示兩種可供修改之程序類型。



當編輯 12 步驟程序時，介面將如左圖所示。



5.軟體應用

進入編輯介面後，於 12 步驟程序 (A) 中，可自由選擇第 1 至第 12 通道 (Well) 進行設定。

然而於 6 步驟程序 (B) 中，通道為配對模式：第 1 通道與第 7 通道配對，第 2 通道與第 8 通道配對，第 3 通道與第 9 通道配對，依此類推。

(A) 12 步驟程序

Step	Well	Temp. (°C)	Mixing Time (min)	Spin Speed (rpm)	Collect Time (min)	Vapor Time (min)	Pause On/Off
1	2		1	3000	0.5	0	Off
2	2		0.1	2000	0	0	Off
3	3		0.1	500	0	0	Off
4	4		0.1	500	0	0	Off
5	5		0.1	500	0	0	Off

(B) 6 步驟程序

Step	Well	Temp. (°C)	Mixing Time (min)	Spin Speed (rpm)	Collect Time (min)	Vapor Time (min)	Pause On/Off
1	5 · 11		0.1	3000	0.1	0	Off
2	1 · 7		0.1	500	0.1	0	Off
3	2 · 8		0.1	3000	0.1	0	Off
4	3 · 9		0.1	500	0.1	0	Off
5	4 · 10		0.1	3000	0.1	10	Off

6. 技術支援

如有任何疑問，請嘗試聯繫離您最近的授權經銷商。Taiwan Advance Nanotech Inc. 提供售後服務電話 +886 3 3167568 或通過電子郵件：service@tanbead.com 尋求幫助。

請您在與我們的技術人員交談時提供此儀器序列號，這將有效地解決問題並更準確地回答您的問題。

7. 清潔保養須知

- 每次使用後請清潔設備。若使用者發現樣本或試劑有溢出情形，請立即清潔設備，以避免損壞或污染。
- 清潔時請配戴手套及適當個人防護裝備。若設備曾處理具生物危害性之樣本，請依貴單位指引處理所有使用後之清潔用品。
- 儀器可能在磁棒未裝設防護裝置的情況下執行程序，若發生此狀況，請立即清潔磁棒。
- 清潔磁棒時，請使用純水沾濕軟布擦拭，請勿使用酒精類溶劑。
- 若磁棒因污染而生鏽或無法清潔，請聯繫您所在地區之授權經銷商，或聯絡 TANBead (service@tanbead.com) 尋求技術支援。

8. 儀器回收

是否廢棄可能受污染之設備，通常由設備持有者與相關之聯邦、州及地方主管機關協商後決定。在評估應予以廢棄之設備時，設備持有者須考量各產品之當前狀況與潛在安全風險。

電池資訊:

本產品內含符合歐盟電池法規 Regulation (EU) 2023/1542 之電池。該電池已通過化學成分限制及 CE 合格評估。使用後請依當地回收規範處理，請勿與生活垃圾一併丟棄。

9. 專利

專利列表

美國	US09616398B2
歐洲	EP2937136
加拿大	CA2862946
日本	JP6151735B2
韓國	KR101696517B1
中國	CN104971638B
台灣	TWI526245B
世界智慧財產權組	WO2016127292

10. 製造業者及器材商資訊



- 製造廠名稱：台灣圓點奈米技術股份有限公司儀器林口廠
- 製造廠地址：333桃園市龜山區文禾路188號4樓
- 製造廠電話：03-3167568

11. 重要通告資訊

本公司可能會不定期發佈重要通告（包含安全提示、操作強化說明或產品修正建議），以保障使用安全與產品效能。

最新通告請聯絡本公司客服窗口：service@tanbead.com

本公司對已發佈之通告將保留分發與簽收紀錄，並在必要時通知代理商與使用單位採取相應行動。

13. TANBead 儀器保固政策

本保固條款適用於台灣圓點奈米技術股份有限公司（以下簡稱 TANBead）所製造之核酸萃取儀。

TANBead 保證於正常使用條件下，本產品自購買日起一年內不會產生材料或製造上的缺陷。如於保固期間內發現產品有任何瑕疵，TANBead 將提供免費維修或更換服務。

以下情況不適用於本保固政策：

- 因使用、操作、儲存、保養不當、誤用或運輸過程中造成之損壞
- 因意外、災害、天然現象或其他不可抗力因素造成之損壞
- 經未授權人員改裝、拆解、重組或維修者
- 產品超過其使用期限或未依使用說明操作
- 因非 TANBead 可控因素（如樣本品質、實驗條件或操作錯誤）所導致之損壞或損失

提出保固申請時，請提供以下資訊：

- 購買憑證（發票、收據等）
- 產品名稱（型號）與序號
- 問題描述及相關證明（如照片、測試結果等）

我們將提供產品退回流程指引。請勿在未獲授權情況下直接退回產品。TANBead 將負擔產品退回之運費，但不承擔其他相關費用或損失。

本保固政策為您唯一之補償條款，並取代其他明示或暗示之保證條件。TANBead 不對任何間接、特殊、附帶或衍生性損害負責，包括但不限於利潤損失、業務中斷、資料遺失或其他商業損失。

感謝您選擇 TANBead，我們致力於提供讓您滿意的產品與服務。若有任何疑問，歡迎隨時聯絡我們（service@tanbead.com）。

如欲獲得更多技術支援與服務，請註冊加入 TANBead 官方會員。

